

Assessment Criteria for Considering Applications for Solar Photovoltaic System
made under Section 16 of the Town Planning Ordinance

Feed-in Tariff and Solar Photovoltaic System

1. Development of renewable energy (RE) is an important part of the Government's efforts in combating climate change. Increasing the use of RE, a zero-carbon energy, can help decarbonize the electricity generation sector, which contributes to about two-thirds of the carbon emissions in Hong Kong. The policy is for the Government to take the lead in developing RE where technically and financially feasible and to create conditions that are conducive to community participation. Against this background, Feed-in Tariff (FiT) was introduced under the post-2018 Scheme of Control Agreements (SCAs) between the Government and the two power companies, i.e. The Hongkong Electric Company, Limited (HKE) and CLP Power Hong Kong Limited (CLP) to provide incentives for individuals and non-Government bodies to invest in RE, including solar photovoltaic (SPV) system. Under the SCAs, FiT is offered for electricity generated by the RE systems throughout the project life of the RE systems¹ or until 31 December 2033, whichever is the earlier.
2. A SPV system includes SPV panels, inverter(s), energy meters, distribution board(s), cables and other components as necessary to form a complete grid connected SPV installation. The two key components are SPV panels and inverter(s). SPV panels convert sunlight into electricity. The inverter(s) convert the output direct current (DC) of the solar panels into alternating current (AC). A typical SPV system is shown in **Figure 1**.

Statutory Planning Provision for Solar Photovoltaic System

3. In general, SPV systems are commonly found on (i) rooftop of New Territories Exempted House (NTEH); (ii) rooftop of private buildings; and (iii) vacant land.
4. If installation of SPV system is incidental to, directly related and ancillary to and commensurate in scale with a permitted use/development within the same zone or at the rooftop of NTEH or private building, it is regarded as an ancillary use for supplementing power supply to the use/development, household or building². No planning permission for the system is required.
5. Installation of SPV system as a stand-alone facility on vacant land for the FiT Scheme would be regarded as 'Public Utility Installation' ('PUI'), which is always permitted in "Commercial", "Government, Institution or Community", "Industrial", "Industrial (Group D)", "Open Storage", "Other Specified Uses" ("OU") annotated "Business" and "OU" annotated "Industrial Estate" zones. Planning application is required for stand-alone SPV system for FiT Scheme in areas where 'PUI' is a Column 2 use under the statutory plan concerned. Any such planning permission granted would be for 'Public Utility Installation (Solar Photovoltaic System for the FiT Scheme)'. Only temporary approval would be considered where there may be potential impact generated by the proposed SPV system which needs to be closely monitored or that the long-term planning intention of the zone

¹ The lifespan of a SPV system is about 20 to 25 years.

² Installation of SPV system for generating electricity for a permitted use, such as that for a farm, green house/farm structures in the "Agriculture" zone mainly for generating electricity for agricultural purposes, or that installed in connection with NTEH in "Village Type Development" zone, are also regarded as an ancillary use.

may be frustrated by the proposed use.

Assessment Criteria for Planning Applications

6. The following criteria should be taken into account in assessing planning applications for SPV system made under section 16 of the Town Planning Ordinance:
- a) it is a prerequisite for the applicant to obtain the 'Consent Letter' or 'Acknowledgement Letter' from HKE and CLP respectively and submit a copy of the document together with the application to demonstrate the technical feasibility of the scheme in terms of serviceability, electrical safety and output generated by the SPV system;
 - b) unless with strong justifications, the SPV system, including the height of the proposed structures, should be in keeping with the surrounding area/developments and commensurate with the function(s) it performs;
 - c) for optimisation of use of land, favourable consideration may be given if viability of co-existence of the proposed SPV system and uses that are in line with the long-term planning intention of the land use zoning of the application site could be satisfactorily demonstrated;
 - d) it has to be demonstrated to the satisfaction of the relevant government departments that the SPV system will not have significant adverse impacts, including but not limited to those relating to the environment, drainage, sewerage, traffic, geotechnical safety, landscape and visual³ and, where needed, appropriate measures are to be adopted to mitigate the impacts;
 - e) unless with strong justifications⁴, proposals involving extensive site formation, vegetation clearance/tree felling, excavation or filling of land/pond are generally not supported;
 - f) planning applications with proposed felling of existing Old and Valuable Trees (OVTs), potentially registrable OVTs, and trees of rare or protected species should not be supported. If tree removal is unavoidable, subject to the advice of relevant government departments, compensatory tree planting and/or landscape treatments should be provided within the application site as appropriate;
 - g) for SPV system falling within water gathering grounds, information should be provided to the satisfaction of the relevant government departments that the system, including its installation, maintenance and operation, will not contaminate the water supply;

³ The applicant has to demonstrate that the proposal would not affect the visual and landscape amenities/character of the area adversely by, for instance, causing a significant change of landscape resources/character, dwarfing the surrounding developments or catching the public's visual attention due to the scale and prominence of the proposed installation. Where appropriate, measures should be taken to mitigate the visual/landscape impact, for example, by peripheral screen planting.

⁴ Ground-mounted SPV system is usually on steel frame or concrete plinth. It should normally not involve extensive site formation, excavation or filling of land.

- h) where the installation is proposed to be in area close to airports and/or heliports, or major roads, it has to be demonstrated to the satisfaction of the relevant government departments that the SPV system should not cause glare to pilots/drivers and/or unacceptable adverse impact on aviation and/or traffic safety;
- i) the planning intention of "Agriculture" ("AGR") zone is to retain and safeguard good quality agricultural farm land/fish ponds for agricultural purposes. SPV system ancillary to agricultural use would not require planning permission (as explained in Footnote 2 under Paragraph 4). Planning application for stand-alone SPV system as 'PUI' use in the "AGR" zone is generally not supported except those on land with no active farming activities and low agricultural rehabilitation potential. For application on fish ponds in the "AGR" zone, the applicant has to demonstrate that the SPV system will not hinder the use of the site for fisheries purposes;
- j) as there is a general presumption against development in the "Green Belt" ("GB") zone, planning application within the "GB" zone is normally not supported unless with strong justifications. It has to be demonstrated to the satisfaction of the relevant government departments that the SPV system would not adversely affect the landscape character/resources of the "GB" zone and jeopardise the integrity of the zone as a buffer;
- k) due to the sensitive nature of the conservation zones, such as the "Conservation Area", "Coastal Protection Area" and "Site of Specific Scientific Interest" zones, planning application for SPV system within such zones is normally not supported to avoid any possible irreversible damages caused to the ecology or environment of the area within the zone;
- l) all other statutory or non-statutory requirements of the relevant government departments must be met. Depending on the specific land use zoning of the application site, the relevant Town Planning Board guidelines should be observed, as appropriate; and
- m) approval conditions to address the technical issues, if any, within a specified time and clauses to revoke the permission for non-compliance with approval conditions may be imposed as appropriate.

Figure 1

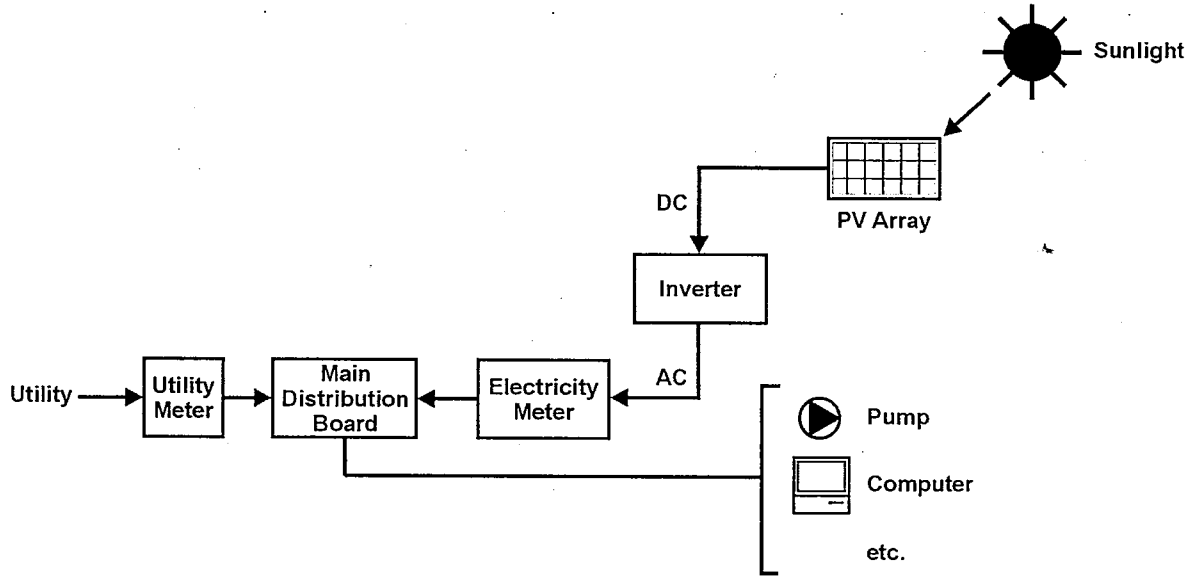

Extracted from EMSD website HK RE Net:
https://re.emsd.gov.hk/english/solar/solar_ph/PV_Systems.html

Typical Solar Photovoltaic System

Recommended Advisory Clauses

- (a) the planning permission is given to the developments/uses under application. It does not condone any other developments/uses which currently occur on the Site but not covered by the application. The applicant shall be requested to take immediate action to discontinue such developments/uses not covered by the permission;
- (b) to note the comments of the District Lands Officer/Yuen Long, Lands Department (DLO/YL, LandsD) as follows:
- (i) the Site comprises an Old Schedule Agricultural Lot held under the Block Government Lease which contains the restriction that no structures are allowed to be erected without the prior approval of the Government; and
 - (ii) the lot owner will need to apply to his office to permit the structures to be erected or regularize any irregularity on site, if any. Besides, given the proposed use is temporary in nature, only application for regularization or erection of temporary structure(s) will be considered. Applications for any of the above will be considered by the LandsD acting in the capacity of the landlord or lessor at its sole discretion and there is no guarantee that such application will be approved. If such application is approved, it will be subject to such terms and conditions, including among others the payment of rent or fee, as may be imposed by the LandsD;
- (c) to note the comments of the Commissioner for Transport (C for T) as follows:
- (i) the Site is connected to the public road network via a section of a local access which is not managed by Transport Department. The land status of the local access should be clarified with LandsD by the applicant. Moreover, the management and maintenance responsibilities of the local access should be clarified with the relevant lands and maintenance authorities accordingly;
 - (ii) as there is no information about the vehicular access at the private lot(s) to the Site, it is presumed that the applicant should arrange by themselves if necessary, and should seek the relevant land owner(s) on the right of using the vehicular access; and
 - (iii) no vehicles are allowed to queue back to or reverse onto/from the Site anytime during the planning approval period;
- (d) to note the comments of the Chief Highway Engineer/New Territories West, Highways Department (CHE/NTW, HyD) as follows:
- adequate drainage measures should be provided to prevent surface water running from the Site to the nearby public roads and drains;
- (e) to note the comments of the Director of Environmental Protection (DEP) as follows:
- the applicant shall strictly comply with relevant pollution control ordinances, including Waste Disposal Ordinance and Water Pollution Control Ordinance and to implement appropriate pollution control measures to minimize any potential environmental impacts

during construction of the project. Reference could be made to relevant publication /guidelines including the following:

- (i) Recommended Pollution Control Clauses for Construction Contracts (available at http://www.epd.gov.hk/epd/english/environmentinhk/eia_planning/guide_ref/rpc.html); and
 - (ii) Professional Persons Environmental Consultative Committee Practice Notes (ProPECC PN) 1/94, "Construction Site Drainage";
- (f) to note the comments of the Director of Agriculture, Fisheries and Conservation (DAFC) as follows:
- (i) the Site is partly paved with some weeds and trees of common species. There were two semi-mature trees at the western boundary of the Site. The two trees should be preserved as far as possible; and
 - (ii) the semi-natural watercourse is located outside the Site. The applicant shall perform good site practice so as not to pollute the semi-natural watercourse.
- (g) to note the comments of the Director of Fire Services (D of FS) as follows:
- (i) in consideration of the design/nature of the proposal, fire services installations (FSIs) are anticipated to be required. Therefore, the applicant is advised to submit relevant layout plans incorporated with the proposed FSIs to his Department for approval. The applicant should also be advised on the following points:
 - (1) the layout plans should be drawn to scale and depicted with dimensions and nature of occupancy; and
 - (2) the location of where the proposed FSIs to be installed should be clearly marked on the layout plans; and
 - (ii) the applicant should be reminded that if the proposed structure(s) is required to comply with the Buildings Ordinance (Cap. 123), detailed fire service requirements will be formulated upon receipt of formal submission of general building plans;
- (h) to note the comments of the Chief Building Surveyor/New Territories West, Buildings Department (CBS/NTW, BD) as follows:
- (i) if the existing structures (not being a New Territories Exempted House) are erected on leased land without approval of the BA, they are unauthorized building works (UBW) under the Building Ordinance (BO) and should not be designated for any approved use under the application;
 - (ii) for UBW erected on leased land, enforcement action may be taken by the BD to effect their removal in accordance with BD's enforcement policy against UBW as and when necessary. The granting of any planning approval should not be construed as an acceptance of any existing works or UBW on the Site under the BO;

- (iii) before any new building works (including containers and open sheds as temporary buildings, demolition and land filling) are to be carried out on the Site, the prior approval and consent of the BA should be obtained, otherwise they are UBW. An Authorized Person should be appointed as the co-ordinator for the proposed building works in accordance with the BO;
 - (iv) the Site shall be provided with means of obtaining access thereto from a street and emergency vehicular access in accordance with Regulations 5 and 41D of the Building (Planning) Regulation (B(P)R) respectively;
 - (v) if the Site does not abut on a specified street of not less than 4.5m wide, its permitted development intensity shall be determined under Regulation 19(3) of the B(P)R at the building plan submission stage; and
 - (vi) detailed comments under the BO will be provided at building plan submission stage;
- (i) to note the comments of the Chief Engineer/Mainland North, Drainage Services Department (CE/MN, DSD) as follows:
- (i) the applicant shall submit a drainage submission to demonstrate how he will collect, convey and discharge rain water falling onto or flowing to his site. A clear drainage plan showing full details of the existing drains and the proposed drains (e.g. cover and invert levels of pipes/catchpits/outfalls and ground levels justifying waterflow etc.) with supporting design calculations and charts should be included. For preparation of the drainage proposal, the guideline on preparation of the drainage proposal is available in DSD homepage at http://www.dsd.gov.hk/EN/Files/Technical_Manual/dsd_guideline/Drainage_Submission.pdf for reference. Approval of the drainage proposal must be sought prior to the implementation of drainage works on site;
 - (ii) after completion of the required drainage works, the applicant shall provide DSD a set of record photographs showing the completed drainage works with corresponding photograph locations marked clearly on the approved drainage plan for reference. DSD will inspect the completed drainage works jointly with the applicant with reference to the set of photographs;
 - (iii) the applicant shall ascertain that all existing flow paths would be properly intercepted and maintained without increasing the flooding risk of the adjacent areas;
 - (iv) no public sewerage maintained by CE/MN, DSD is currently available for connection. For sewage disposal and treatment, agreement from the DEP shall be obtained;
 - (v) the applicant is reminded that the proposed drainage proposal/works as well as the site boundary should not cause encroachment upon areas outside his jurisdiction;

- (vi) all the proposed drainage facilities should be constructed and maintained by the applicant at his own cost. The applicant should ensure and keep all drainage works on site under proper maintenance at all times; and
 - (vii) the applicant should consult DLO/YL, LandsD regarding all the proposed drainage works outside the site boundary in order to ensure the unobstructed discharge from the Site in future; and
- (j) to note the comments of the Director of Electrical and Mechanical Services (DEMS) as follows:

The applicant shall approach the electricity supplier (i.e. CLP Power) for the requisition of cable plans (and overhead line alignment drawings, where applicable) to find out whether there is any underground cable and/or overhead line within or in the vicinity of the application site. Based on the cable plans and the relevant drawings obtained, if there is underground cable and/or overhead line within or in the vicinity of the application site, the applicant shall carry out the following measures:

- (i) For Site within the preferred working corridor of high voltage overhead lines at transmission voltage level 132kV or above as stipulated in the Hong Kong Planning Standards and Guidelines (HKPSG) published by the Planning Department, prior consultation and arrangement with CLP Power is necessary;
- (ii) Prior to establishing any structure within the application site, the applicant and/or his contractors shall liaise with the electricity supplier and, if necessary, ask CLP Power to divert the underground cable and/or overhead line away from the vicinity of the proposed structure; and
- (iii) The Electricity Supply Lines (Protection) Regulation and the "Code of Practice on Working near Electricity Supply Lines" established under the Regulation shall be observed by the applicant when carrying out works in the vicinity of the electricity supply lines.