

Urgent Return receipt Expand Group Restricted Prevent Copy

Adrian Tsz Hin TAM/PLAND

寄件者: Ping Yeung <[REDACTED]>
寄件日期: 2026年06月11日星期四 9:21
收件者: Adrian Tsz Hin TAM/PLAND
主旨: Re: Planning application No. A/NE-TKL/826 - Proposed Temporary Private Vehicle Park (Private Cars and Van-Type Light Goods Vehicles Only) for a Period of 3 Years
附件: Swept path analysis for Ping Yuen Rd private car parking spaces 3.pdf
類別: Internet Email

致:譚先生

就 TKL/826 申請,須補充資料給運輸署,現附上文件,如有任何意見,請電郵我。

坪洋村村務委員會
吳小姐

From: Adrian Tsz Hin TAM/PLAND <athtam@pland.gov.hk>
Sent: Friday, May 8, 2026 1:38 AM
To: Ping Yeung <[REDACTED]>
Cc: Sheren Si Wai LEE/PLAND <sswlee@pland.gov.hk>; Johnny Chung Yin LAM/PLAND <jcylam@pland.gov.hk>
Subject: Re: Planning application No. A/NE-TKL/826 - Proposed Temporary Private Vehicle Park (Private Cars and Van-Type Light Goods Vehicles Only) for a Period of 3 Years

Dear Ms. Ng,

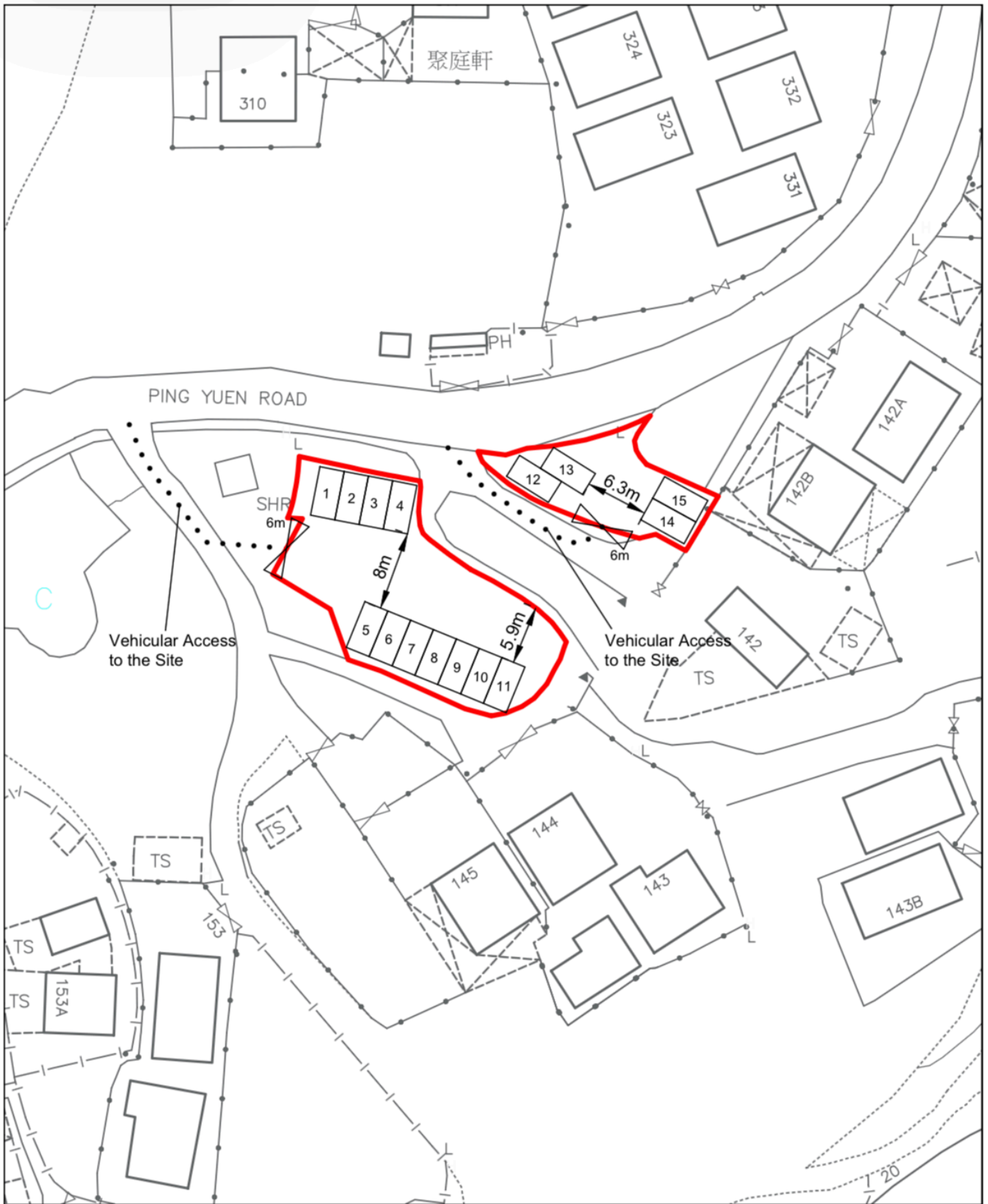
Please find the following comment from the Transport Department (TD) on the FI submission.

Comment from TD

- The previous comments on manoeuvring have not been addressed.

Many thanks.

Regards,
Adrian TAM
TPG/N1
Sha Tin, Tai Po & North District Planning Office
Planning Department
Tel: 2158 6236



Legend:

- Application Site
- Parking Spaces for Private Vehicles (2.5m x 5m)

Scale 1:500

**Figure 1
Layout Plan**

Swept path “In” for parking space No. 1 to 9

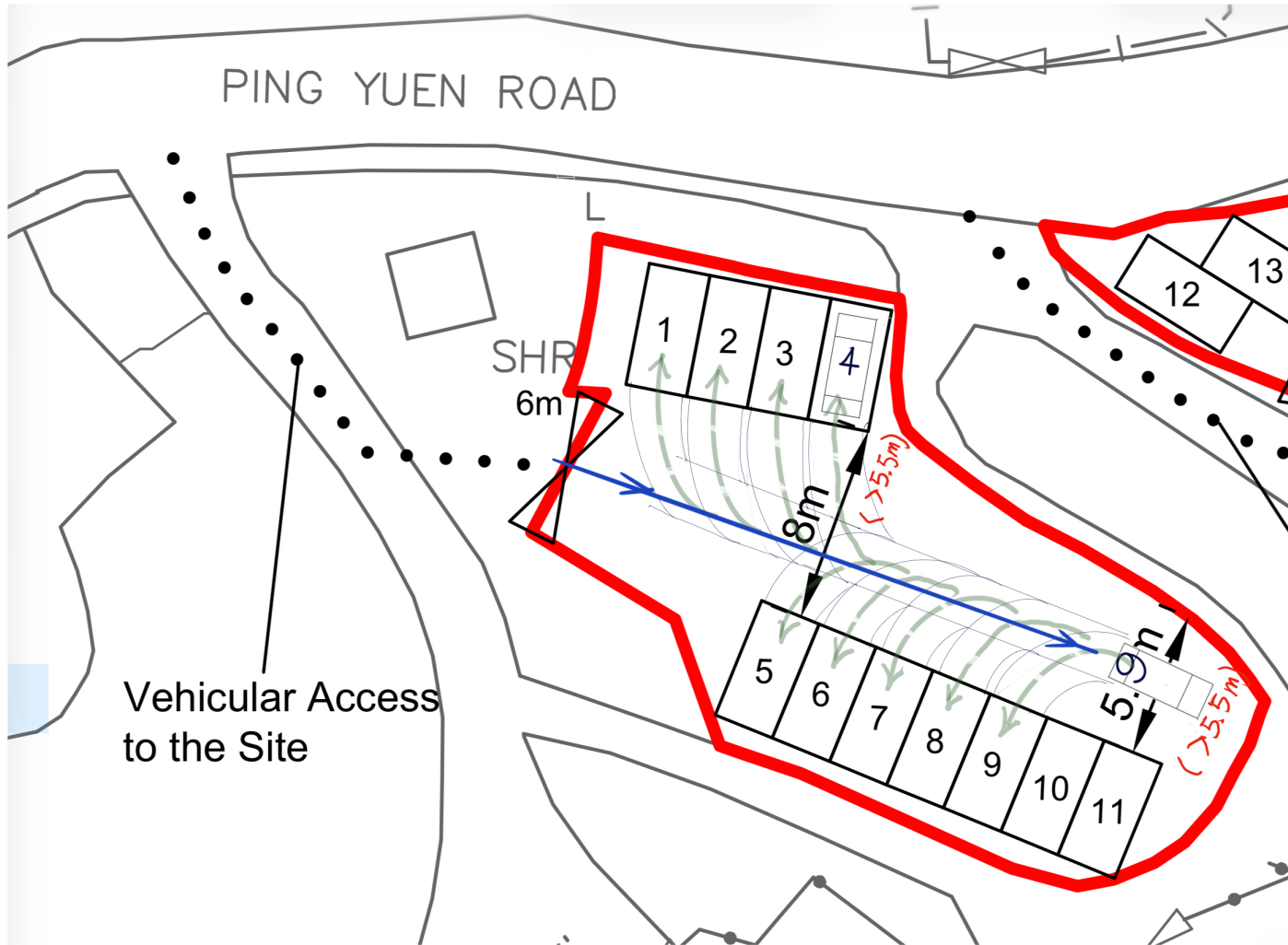
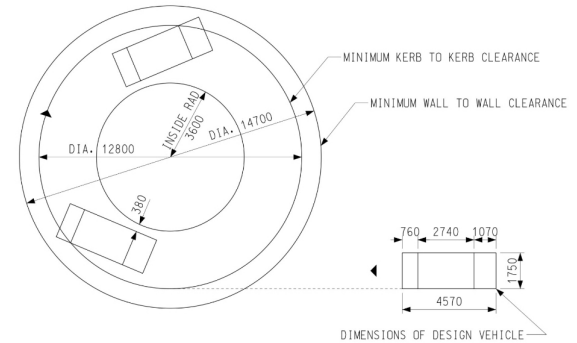
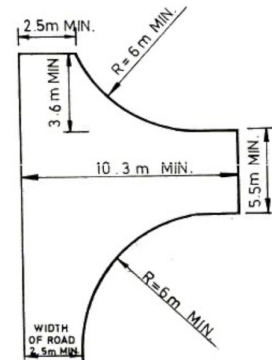


DIAGRAM 2.2.3.1 : RECOMMENDED MINIMUM STANDARDS OF TURNING CIRCLE FOR PRIVATE CARS



March 2026 Edition

MINIMUM TURNING AREA FOR PRIVATE CARS (TYPE B)



Legend:

Vehicle forward 

Vehicle backward 

Swept path "In" for parking space No. 10 to 11

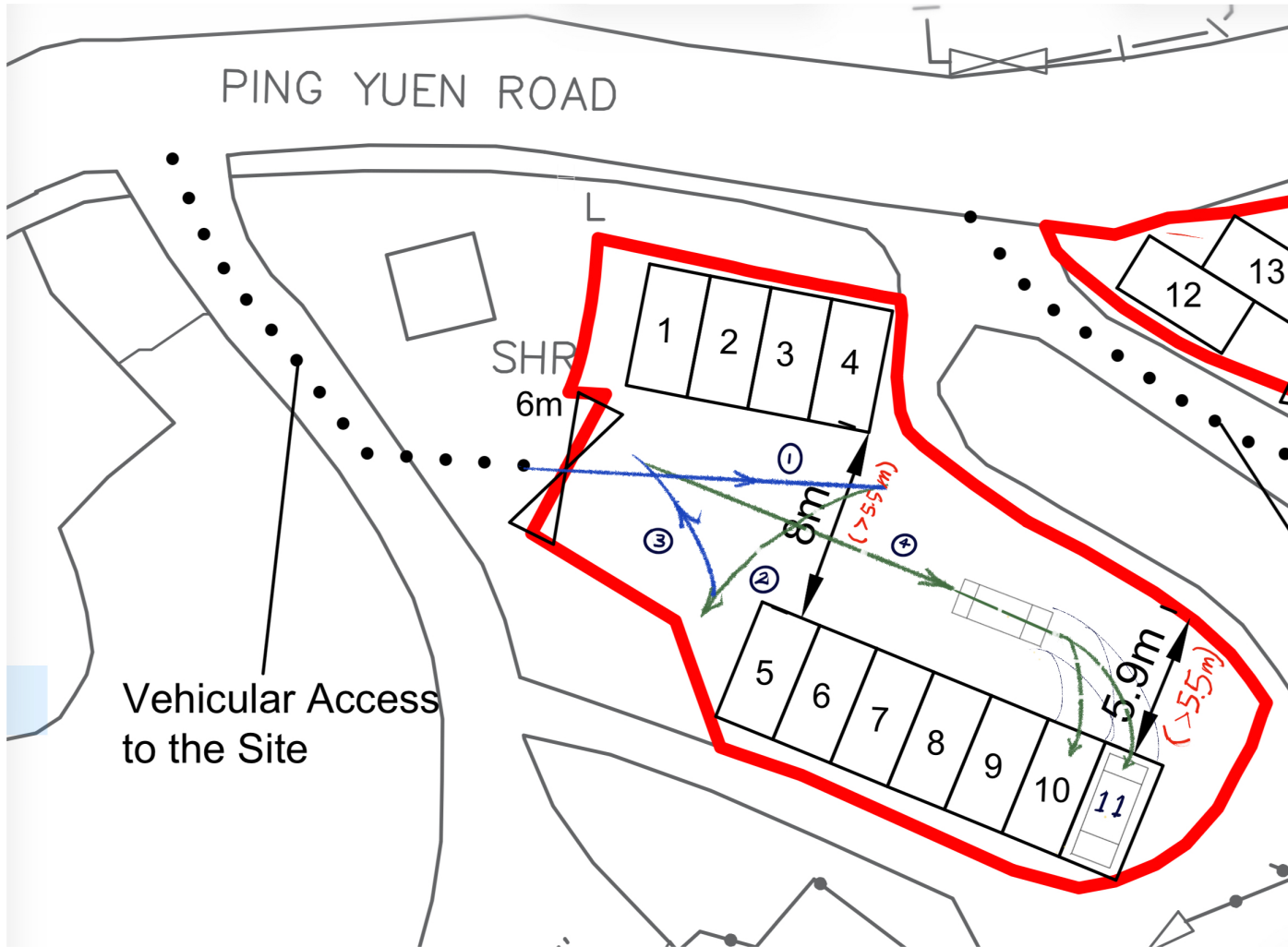
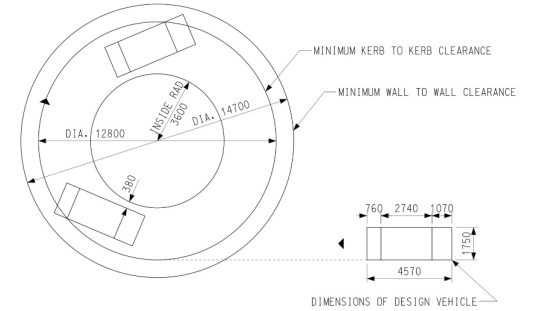
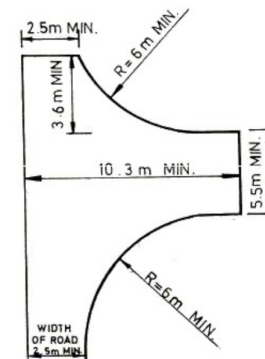


DIAGRAM 2.2.3.1 : RECOMMENDED MINIMUM STANDARDS OF TURNING CIRCLE FOR PRIVATE CARS



March 2026 Edition

MINIMUM TURNING AREA FOR PRIVATE CARS (TYPE B)

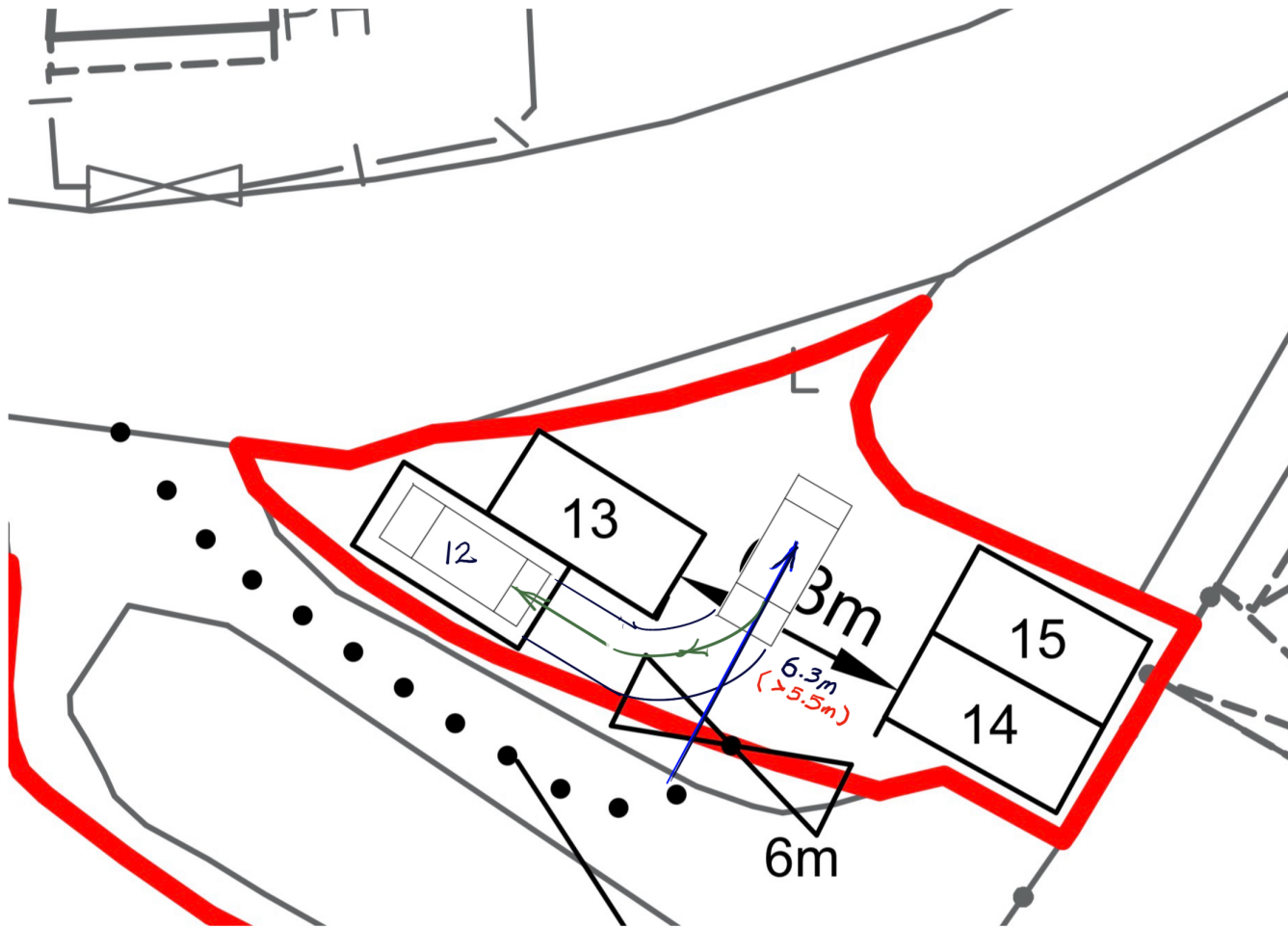


Legend:

Vehicle forward

Vehicle backward

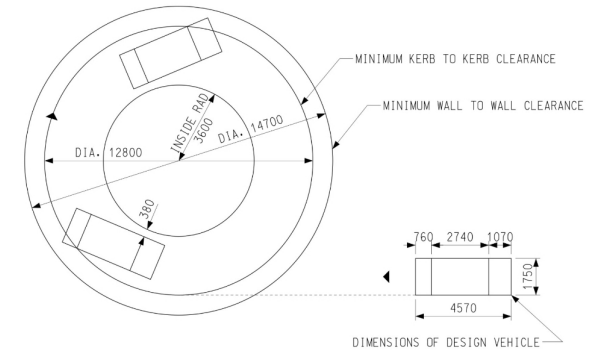
Swept path "In" for parking space No.12



Legend:

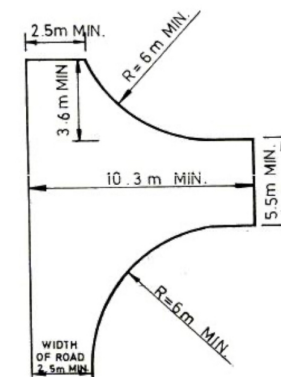
Vehicle forward  Vehicle backward 

DIAGRAM 2.2.3.1 : RECOMMENDED MINIMUM STANDARDS OF TURNING CIRCLE FOR PRIVATE CARS

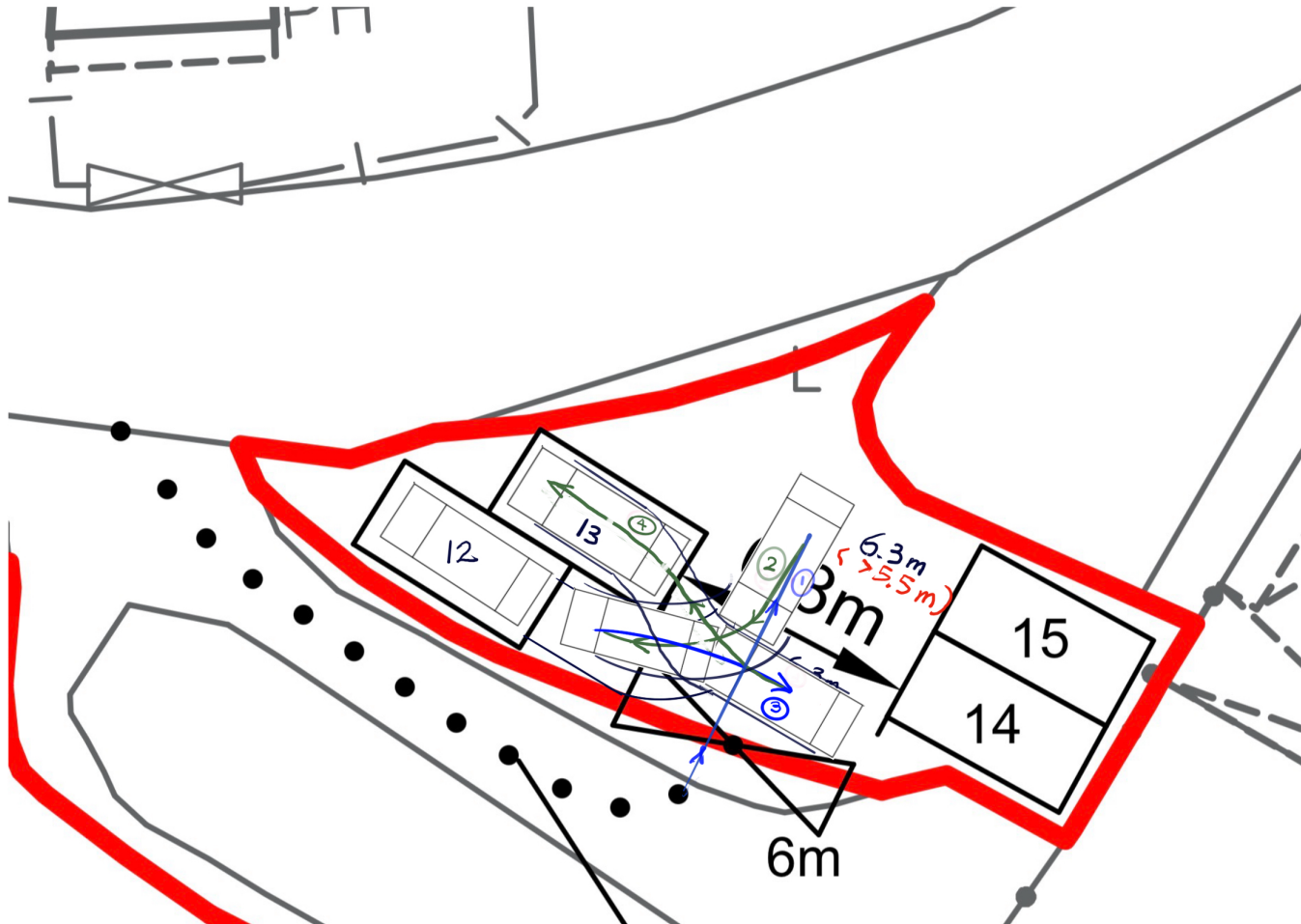


March 2026 Edition

MINIMUM TURNING AREA FOR PRIVATE CARS (TYPE B)



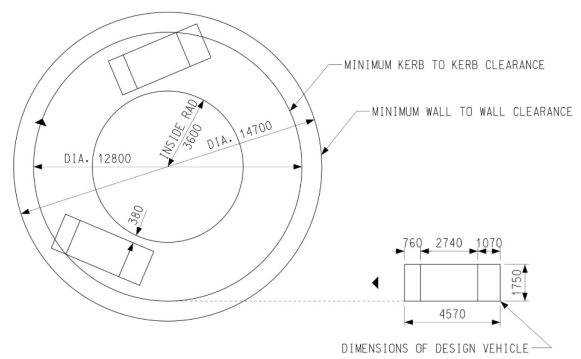
Swept path "In" for parking space No.13



Legend:

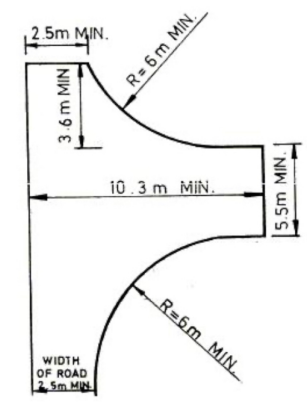
Vehicle forward  Vehicle backward 

DIAGRAM 2.2.3.1 : RECOMMENDED MINIMUM STANDARDS OF TURNING CIRCLE FOR PRIVATE CARS

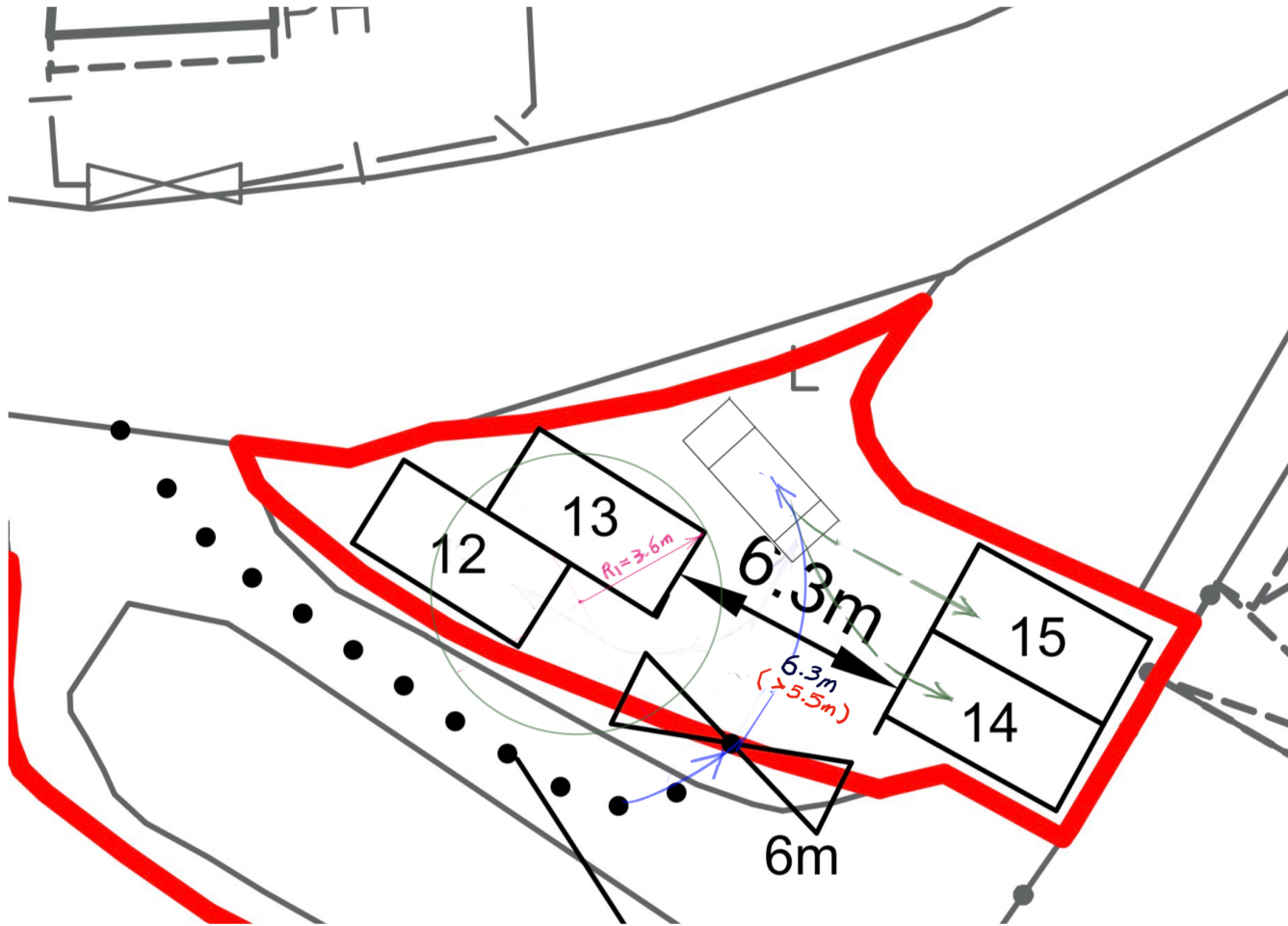


March 2026 Edition

MINIMUM TURNING AREA FOR PRIVATE CARS (TYPE B)



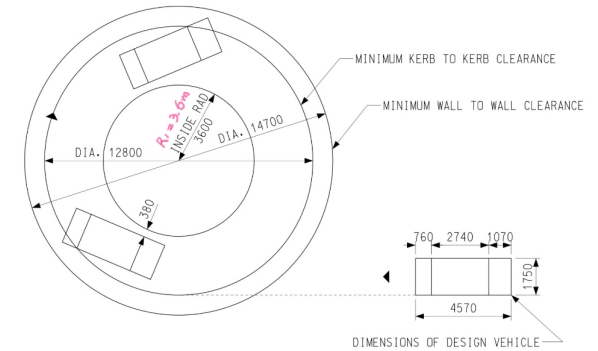
Swept path "In" for parking space No.14, 15



Legend:

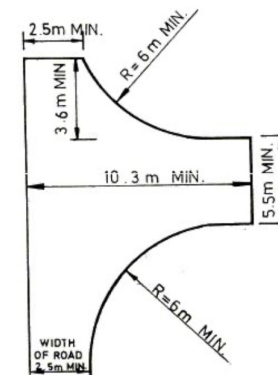
Vehicle forward  Vehicle backward 

DIAGRAM 2.2.3.1 : RECOMMENDED MINIMUM STANDARDS OF TURNING CIRCLE FOR PRIVATE CARS



March 2026 Edition

MINIMUM TURNING AREA FOR PRIVATE CARS (TYPE B)



Swept path “Out” for parking space No. 1-4

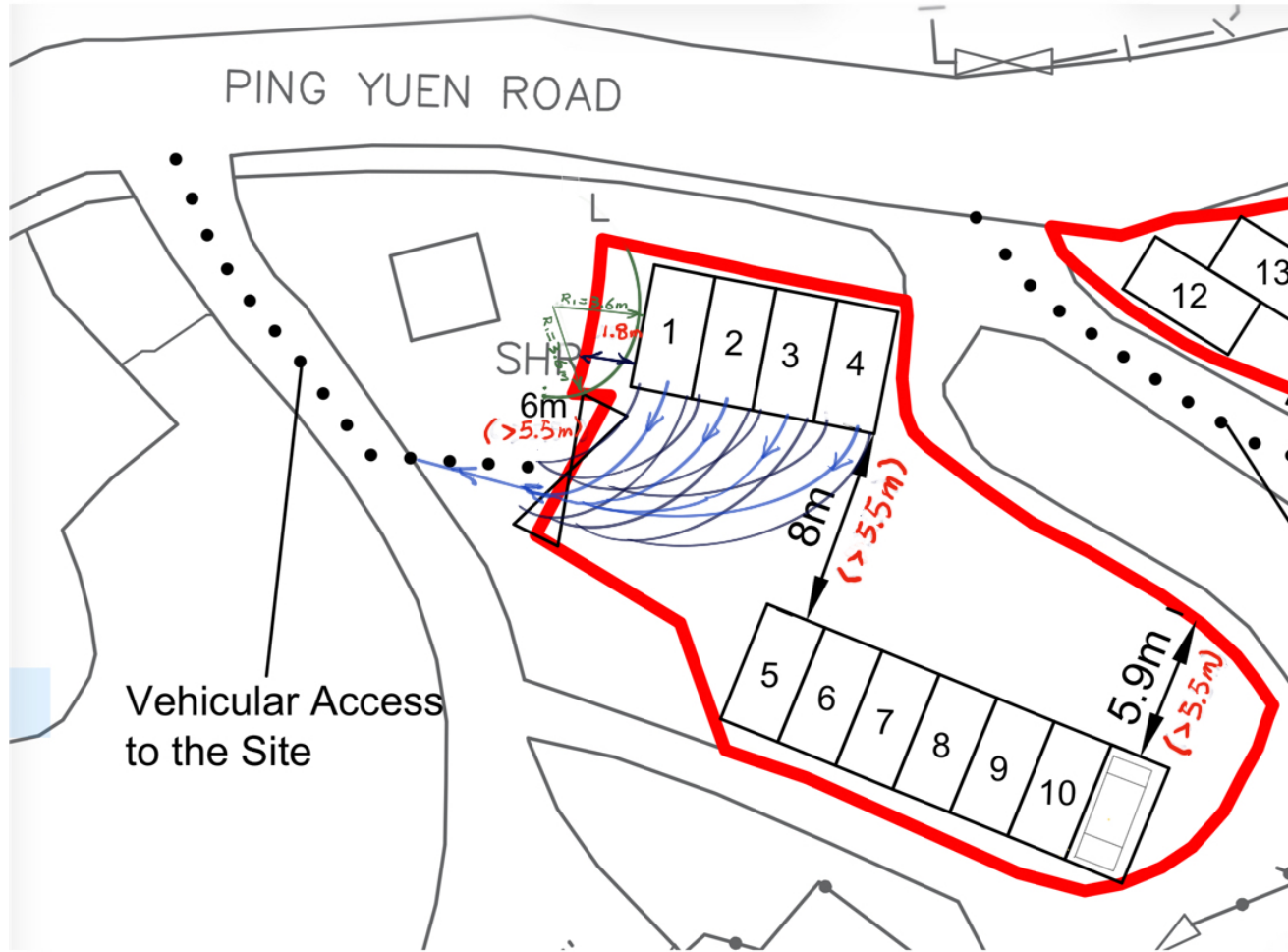
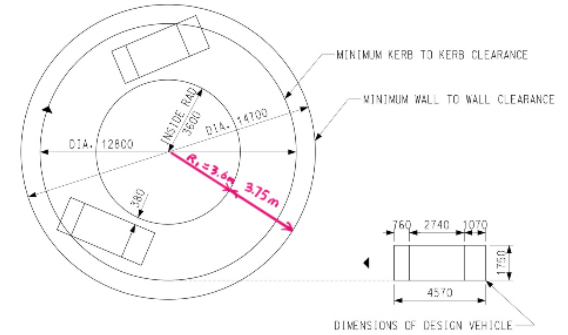
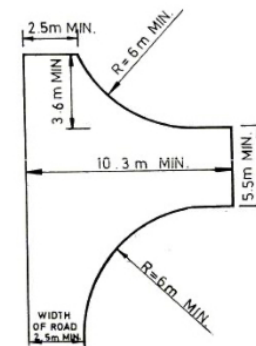


DIAGRAM 2.2.3.1 : RECOMMENDED MINIMUM STANDARDS OF TURNING CIRCLE FOR PRIVATE CARS



March 2026 Edition

MINIMUM TURNING AREA FOR PRIVATE CARS (TYPE B)



Legend:

Vehicle forward \longrightarrow

Vehicle backward \dashrightarrow

Swept path “Out” for parking space No. 5-11

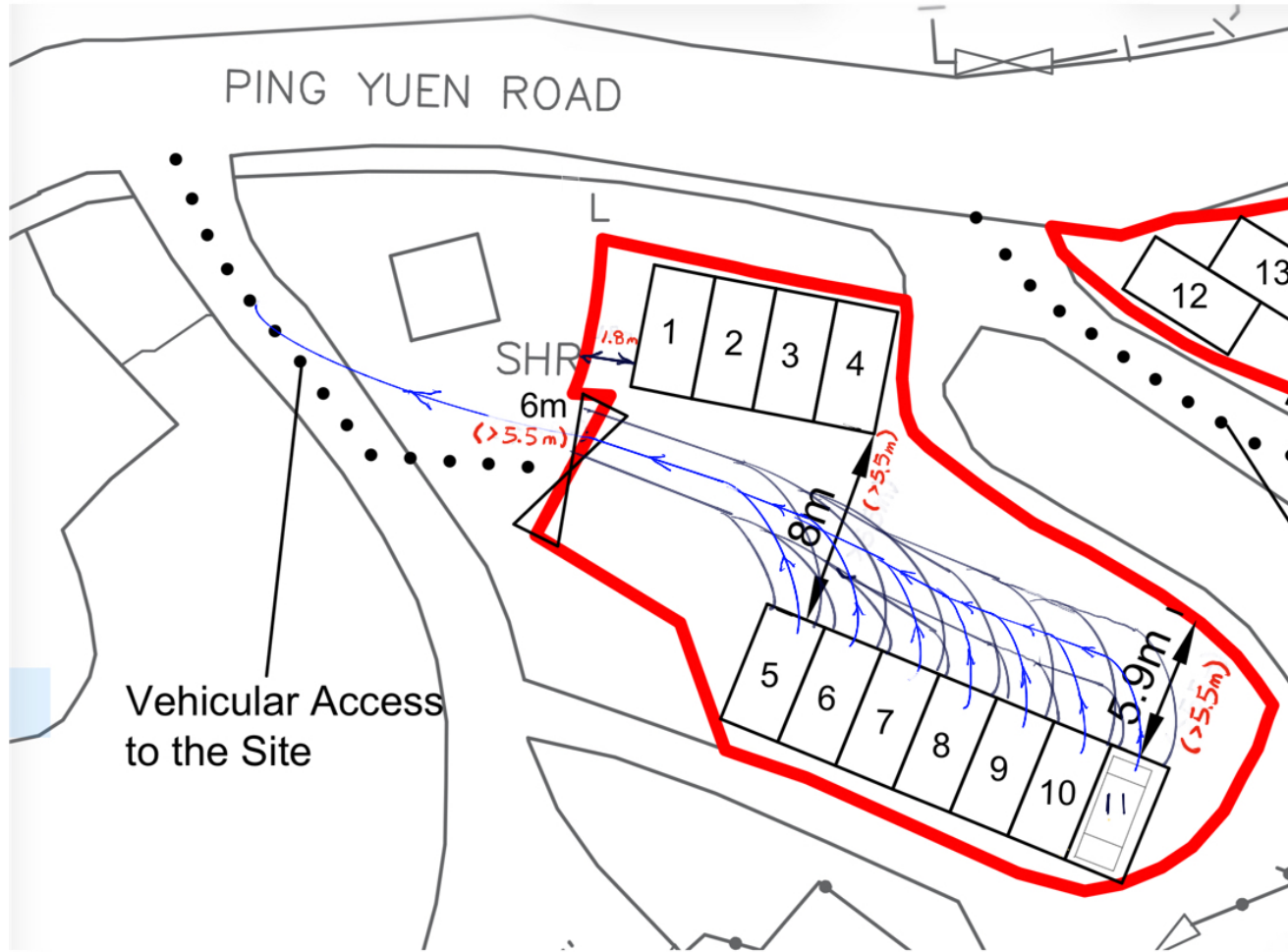
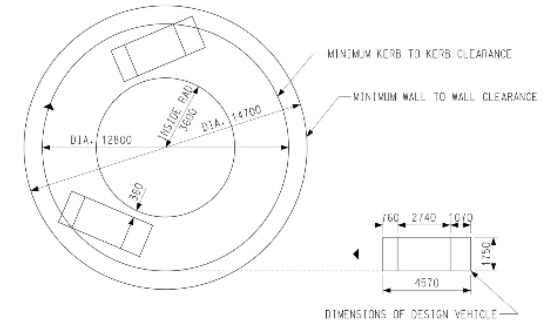
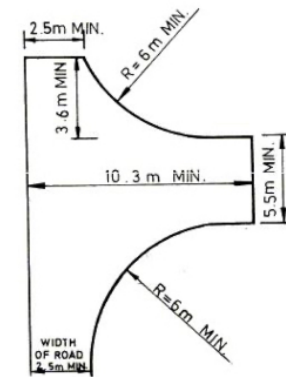


DIAGRAM 2.2.3.1 : RECOMMENDED MINIMUM STANDARDS OF TURNING CIRCLE FOR PRIVATE CARS



March 2026 Edition

MINIMUM TURNING AREA FOR PRIVATE CARS (TYPE B)

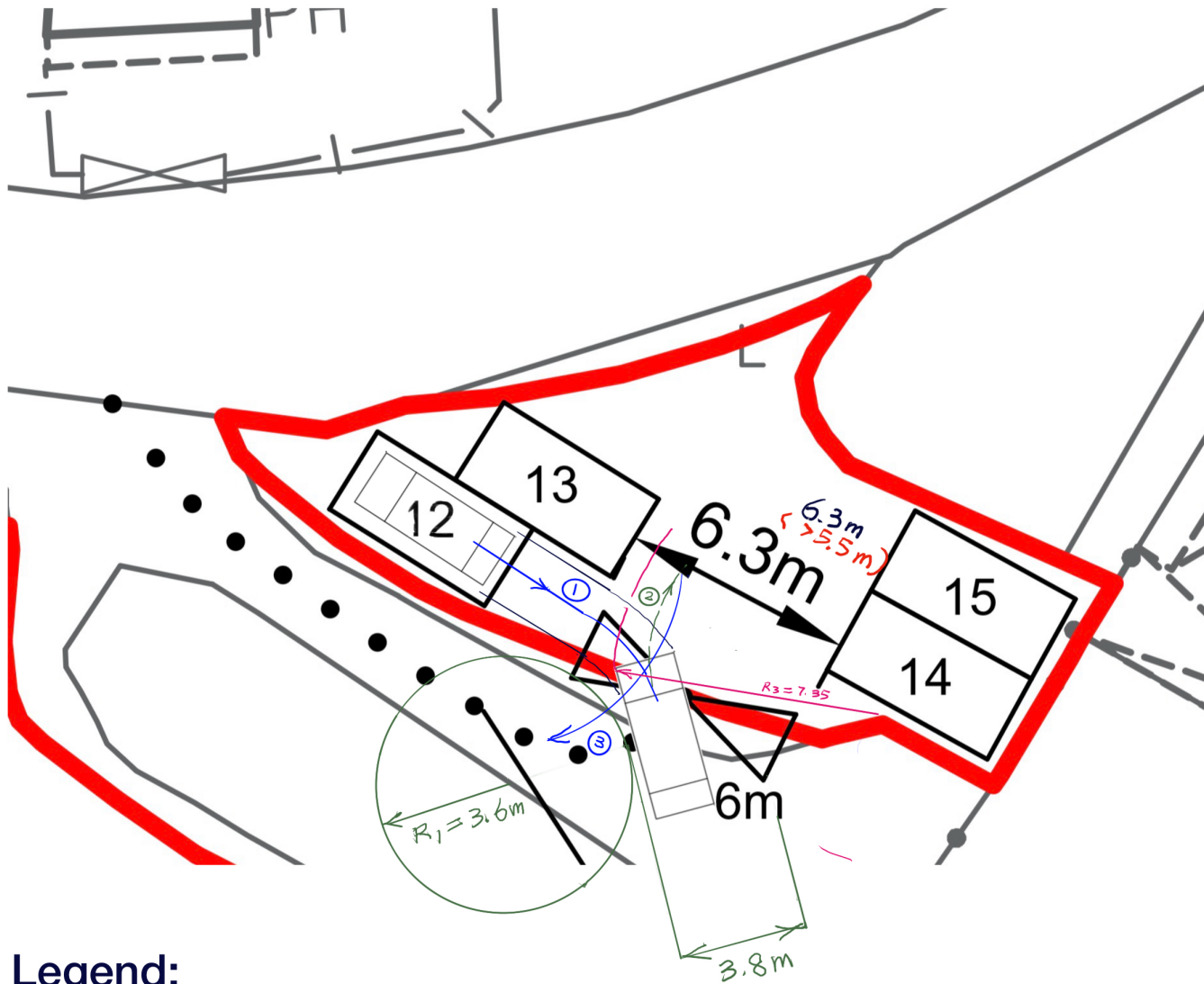


Legend:

Vehicle forward →

Vehicle backward →

Swept path "Out" for parking space No.12



Legend:

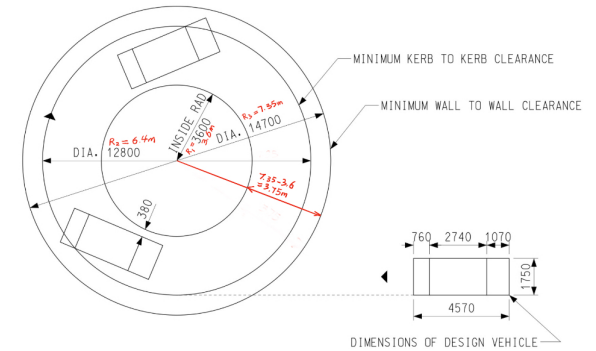
Vehicle forward



Vehicle backward

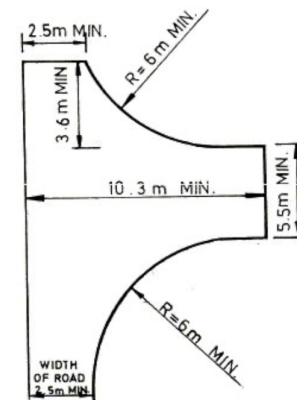


DIAGRAM 2.2.3.1 : RECOMMENDED MINIMUM STANDARDS OF TURNING CIRCLE FOR PRIVATE CARS

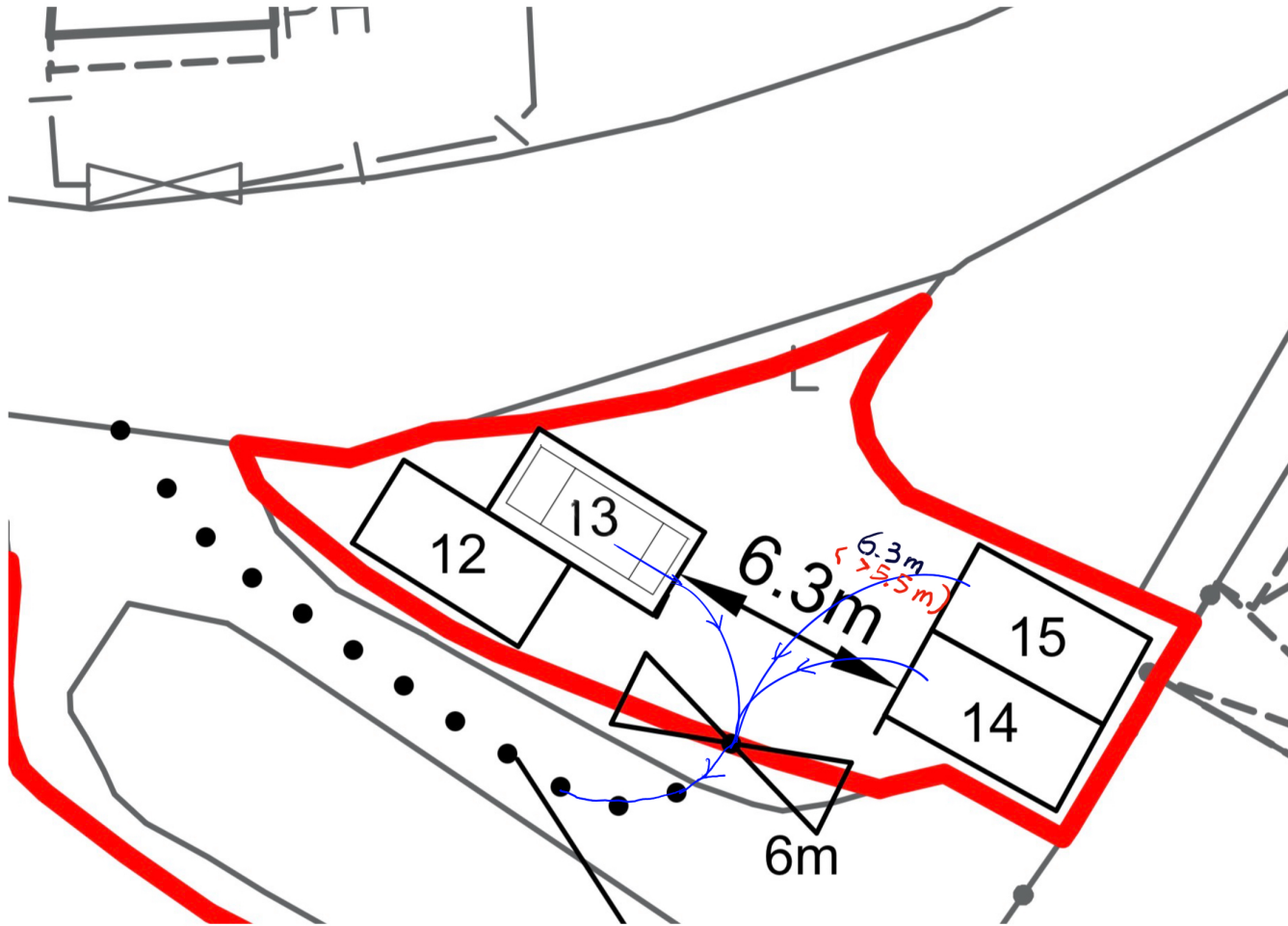


March 2026 Edition

MINIMUM TURNING AREA FOR PRIVATE CARS (TYPE B)



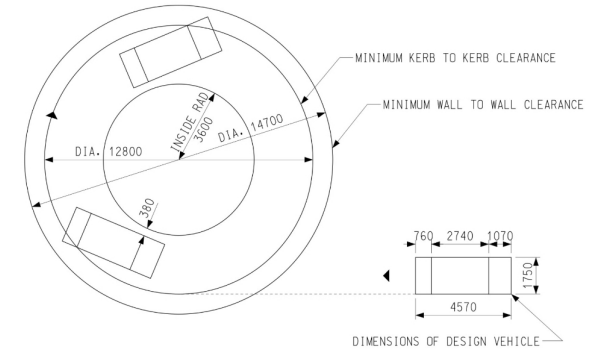
Swept path "Out" for parking space No.13,14 and 15



Legend:

Vehicle forward  Vehicle backward 

DIAGRAM 2.2.3.1 : RECOMMENDED MINIMUM STANDARDS OF TURNING CIRCLE FOR PRIVATE CARS



March 2026 Edition

MINIMUM TURNING AREA FOR PRIVATE CARS (TYPE B)

