寄件者: Christian Chim <[REDACTED]>
寄件日期: 2026年03月27日星期五 12:20
收件者: tpbpd/PLAND
副本: Andrea Wing Yin YAN/PLAND; Ivan Sze Yuet FUNG/PLAND; Bon Tang; Matthew Ng;
Louis Tse; Danny Ng; Grace Wong
主旨: RE: [FI] S.16 Planning Application No. A/YL-KTN/1219 - Further Information
附件: FI1 for A_YL-KTN_1219 (20260327).pdf
類別: Internet Email

Dear Sir,

We write to submit further information in response to departmental comments on the captioned application. This is **to supersede** our previous FI submission in the preceding message dated 24.3.2026 at 18:14hr.

Should you require more information, please do not hesitate to contact us. Thank you for your kind attention.

Kind Regards,

Christian CHIM | Town Planner
R-riches Group (HK) Limited

R-riches Property Consultants Limited | R-riches Planning Limited | R-riches Construction Limited

From: Christian Chim
Sent: Tuesday, March 24, 2026 6:14 PM
To: Town Planning Board <[REDACTED]>
Cc: Andrea Wing Yin YAN/PLAND <awyyan@pland.gov.hk>; 'Ivan Sze Yuet FUNG/PLAND' <isyfung@pland.gov.hk>; Bon Tang <[REDACTED]>; Matthew Ng <[REDACTED]>; Louis Tse <[REDACTED]>; Danny Ng <[REDACTED]>; Grace Wong <[REDACTED]>
Subject: [FI] S.16 Planning Application No. A/YL-KTN/1219 - Further Information

Dear Sir,

We write to submit further information in response to departmental comments on the captioned application.

Should you require more information, please do not hesitate to contact us. Thank you for your kind attention.

Kind Regards,

Christian CHIM | Town Planner
R-riches Group (HK) Limited

R-riches Property Consultants Limited | R-riches Planning Limited | R-riches Construction Limited

Our Ref. : DD 107 Lot 1819 & VL
Your Ref. : TPB/A/YL-KTN/1219

The Secretary,
Town Planning Board,
15/F, North Point Government Offices,
333 Java Road,
North Point, Hong Kong

By E-mail

27 March 2026

Dear Sir,

1st Further Information

**Proposed Temporary Warehouse (excluding Dangerous Goods Godown)
and Open Storage of Construction Materials and Machinery for a Period of 3 Years in
“Comprehensive Development Area(1)” Zone, Lots 1750A9 (Part), 1819 (Part), 1820 (Part),
1821, 1822 (Part) and 1905 RP (Part) in D.D. 107, Kam Tin, Yuen Long, New Territories**

(S.16 Planning Application No. A/YL-KTN/1219)

We write to submit further information in response to departmental comments on the captioned application.

Should you require more information regarding the application, please contact our Mr. Danny NG at [REDACTED] or the undersigned at your convenience. Thank you for your kind attention.

Yours faithfully,

For and on behalf of
R-riches Planning Limited



Christian CHIM
Town Planner

cc DPO/FSYLE, PlanD

(Attn.: Ms. Andrea YAN
(Attn.: Ms. Ivan FUNG

email: awyyan@pland.gov.hk)
email: isyfung@pland.gov.hk)

Response-to-Comment (RtC)

**Proposed Temporary Warehouse (excluding Dangerous Goods Godown)
and Open Storage of Construction Materials and Machinery for a Period of 3 Years in
“Comprehensive Development Area(1)” Zone, Lots 1750A9 (Part), 1819 (Part), 1820 (Part),
1821, 1822 (Part) and 1905 RP (Part) in D.D. 107, Kam Tin, Yuen Long, New Territories**

(S.16 Application No. A/YL-KTN/1219)

- (i) The applicant provides a drainage proposal to alleviate the potential drainage impacts to the surrounding areas. Please refer to **Annex 1** for details.
- (ii) An RtC table:

Departmental Comments		Applicant’s Responses
1. Comments of the Director of Environmental Protection (DEP)		
(a)	The applicant should confirm whether the proposed use would involve storage of materials of dusty nature (e.g., cement, earth, pulverised fuel ash, aggregates, silt, stonefines, sand, debris, sawdust and wooden chips). If affirmative, whether those materials are packaged.	Section 1.2 of the supplementary statement has stated that the proposed warehouse is intended for the storage of miscellaneous goods such as packaged food, apparel, footwear, electronic goods, furniture etc.; whereas the open storage is intended for the storage of construction materials such as steel beam, bricks, scaffold etc. and machinery such as generator, elevated platform etc. The materials to be stored at the application site are not dusty in nature. No storage of dusty materials will be allowed at any time during the approval period of the planning permission.

Annex 1
Drainage Proposal



SUBMISSION REPORT
FOR
DRAINAGE PROPOSAL DESIGN
FOR TEMPORARY WAREHOUSE (EXCLUDING DANGEROUS
GODOWN) AND OPEN STORAGE OF CONSTRUCTION MATERIALS,
MACHINERY AND CONTAINER FOR A PERIOD OF 3 YEARS
ON
LOT 1819, 1820, 1821, 1822(PART) AND 1905(PART) IN D.D.107
KAM TIN, YUEN LONG, N.T.

Report No. SD/1819/001

Date : March 2026

TABLE OF CONTENTS

1. Introduction
2. Existing Drainage Condition
3. Design parameters & assumptions
4. Proposed Stormwater Drainage
5. Effect on Drainage Characteristics and potential Drainage Impacts
6. Conclusions

APPENDIX

- | | |
|------------|-----------------------------------|
| Appendix A | Stormwater Drainage Proposal Plan |
| Appendix B | Surface Drainage Design |

REFERENCES

1. Stormwater Drainage Manual, Planning Design and Management by DSD
2. Geotechnical Manual for Slopes by GEO
3. Standard Drawings by DSD

1. Introduction

This proposal is prepared for the proposed stormwater drainage works for the proposed temporary warehouse (excluding dangerous godown) and open storage of construction materials, machinery and container for a period of 3 years on lot 1819, 1820, 1821, 1822(part) and 1905(part) in D.D.107, Kam Tin, Yuen Long, N.T.

2. Existing Drainage Condition

A plan showing the existing catchments are enclosed in **Appendix B**. Currently, the surface runoff collected from the site is discharging to the existing 700mm dia. pipe and terminated to the existing government 6.5m wide open channel (SCP1009605) as shown in **Appendix A**. As per the existing site condition, additional peripheral U-channels area considered necessary for the proposed development. Drainage proposal is required to be carried out for the proposed development.

3. Design Parameters & Assumptions

The design criteria to be used for the modeling assessment are based on the standards set out in the Stormwater Drainage Manual, Fifth Edition (SDM). According to Section 6.6.1 of the SDM, the existing village drainage system in the vicinity of the development is classified as main rural catchment drainage system. Table 10 of the SDM recommends to be adopted a 50 year design return period storm event for the main rural drainage branch system.

Stormwater Runoff (Q)

The rate of stormwater runoff used in this assessment report is estimated by the “Rational method” in which the peak runoff is calculated from the formula:

$$Q = K \times i \times A / 3600$$

where

Q	=	maximum runoff (L/s)
i	=	design mean intensity of rainfall (mm/hr)
A	=	area of catchment (m ²)
K	=	runoff coefficient

Time of Concentration (tc)

The time of concentration is defined as the time required for stormwater runoff to flow from the most remote part of the catchment area to the point in the drainage system under consideration. Based on the assumptions adopted in the Rational Method, this is the time taken for the peak runoff to become established at the considered section.

The time of concentration comprises the time for water flowing within natural catchments and along the man-made drainage pipes/channels. For natural catchments, the time of concentration is estimated by the modified form of the Brandsby William's equation.

$$t_o = \frac{0.14465L}{H^{0.2} A^{0.1}}$$

Where t_o = time of concentration of a natural catchment (min.)

A = catchment area (m²)

H = average slope (m per 100m), measured along the line of natural flow, from the summit of the catchment to the point under consideration

L = distance (on plan) measured on the line of natural flow between the summit and the point under consideration (m)

Mean Rainfall Intensity (i)

Mean rainfall intensity-duration curves attached in this report are based on the Statistical analysis of long term rainfall records from the Hong Kong Observatory. A return period of 50 years is adopted.

Runoff Coefficient (K)

The value of K is taken as 0.95 for developed area. For vegetated ground, the value of K is taken as 0.3.

4. Proposed Stormwater Drainage

The proposed stormwater drainage works include surface U-channels at the peripheral of the site collecting the runoff from catchments within the site. The U-channels will connect and discharge the surface runoff to the existing government open channel. Catchpits with 300mm sump are proposed at the discharged points of proposed U-Channel to desilt the surface water before discharging to the drainage outside. The proposed stormwater drainage layout plan is shown in **Appendix A**.

5. Effect on Drainage Characteristics and Potential Drainage Impact

The drainage design of the proposed U-channel are presented in **Appendix B**.

6. Conclusion

Peripheral channels are to be provided along the site boundary where necessary to intercept runoff from crossing the site. The drainage conditions of adjacent areas will not be adversely affected.

Appendix A

Stormwater Drainage Proposal Plan

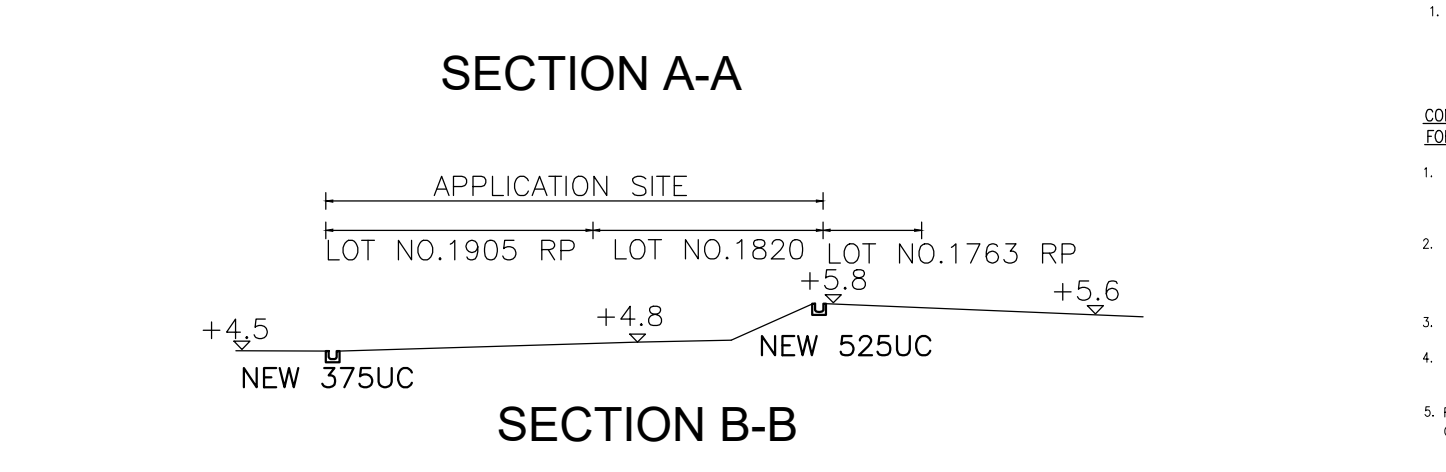
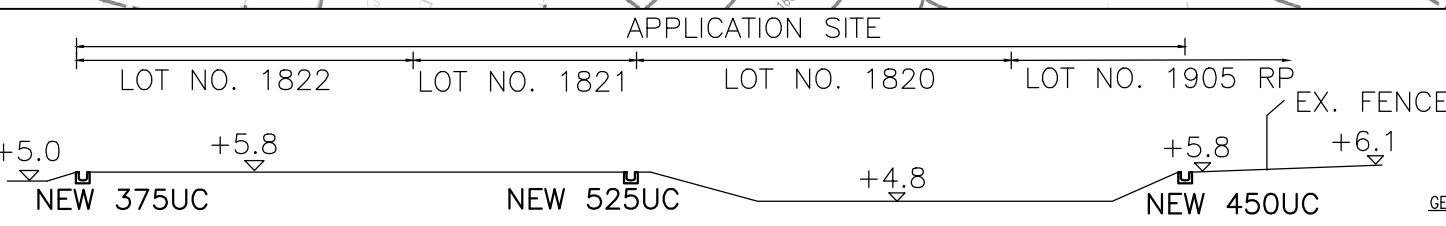
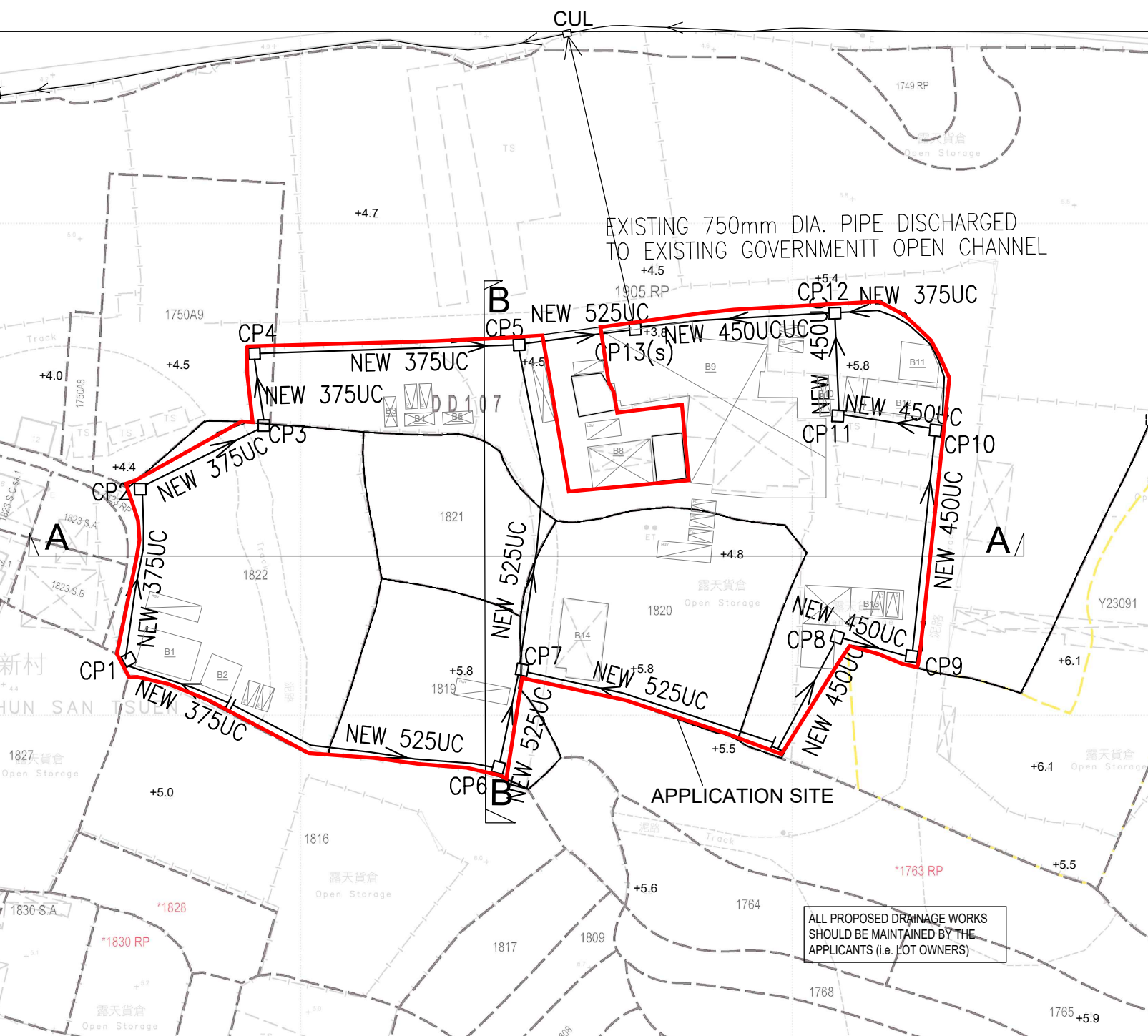

- GENERAL NOTE**
- THE PROPOSED DRAINAGE WORK, WHETHER WITHIN OR OUTSIDE THE LOT BOUNDARY, SHOULD BE CONSTRUCTED AND MAINTAINED BY THE LOT OWNER AT HIS OWN EXPENSE. FOR WORKS TO BE UNDERTAKEN OUTSIDE THE LOT BOUNDARY, PRIOR CONSENT AND AGREEMENT FROM DLO AND/OR RELEVANT PRIVATE LOT OWNER SHOULD BE SOUGHT.
- CONCRETE STRENGTH AND STEEL REINFORCEMENT SPECIFICATION FOR DRAINAGE DETAILS**
- CONCRETE GRADE FOR CATCHPITS AND U-CHANNEL SHALL BE 30D DESIGN IN COMPLIANCE WITH CS1 : 2010 FOR BLINDING LAYER SHALL BE 15D, DESIGN COMPLY WITH CS1-2010.
 - ALL MAIN BARS TO BE HOT ROLLED HIGH YIELD STEEL DEFORMED BAR COMPLI WITH CS2 : 2012
Y - HIGH YIELD BAR 500 MPa
M - MILD STEEL BAR 250 MPa
 - CONCRETE COVER TO MAIN REINFORCEMENT TO BE 50mm.
 - LAP LENGTH FOR ALL BARS TO BE 46x DIAMETER OF LARGER BAR TO BE LAPPED.
 - REACTIVE ALKALI CONTENT EXPRESSED IN SODIUM OXIDE PER CUBIC METER OF CONCRETE SHOULD NOT EXCEED 3KG AS PER PNAP APP-74.

LEGEND:

- NEW 525UC PROPOSED 525mm U-CHANNEL AT FALL 1: 100 (MIN)
- CP13(s) PROPOSED COVERED DESILTED CATCHPIT NO. CP13
- CP1 PROPOSED COVERED CATCHPIT NO. CP1

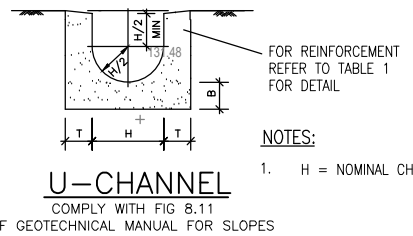
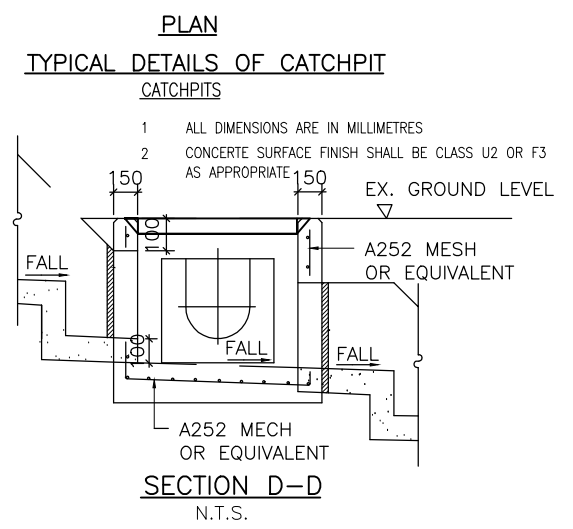
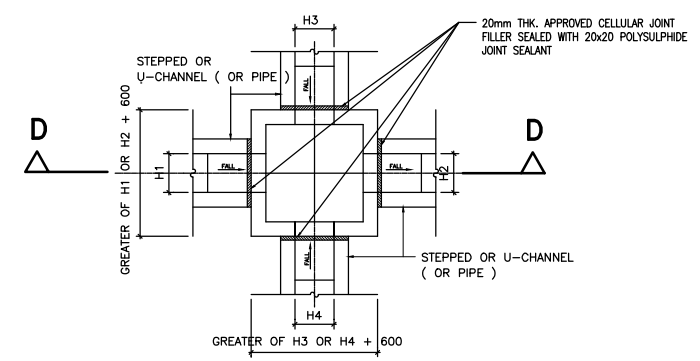
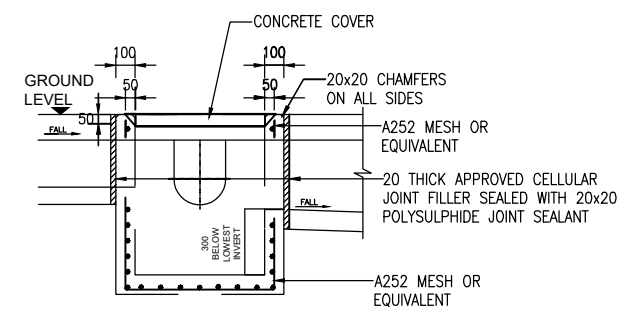

PROPOSED CATCHPIT SCHEDULE

CATCHPIT NO.	C.L. (mPD)	I.L. (mPD)
CP1	5.80	5.22
CP2	5.80	4.88
CP3	5.80	4.60
CP4	5.80	4.45
CP5	4.50	3.85
CP6	5.80	4.72
CP7	5.80	4.53
CP8	5.80	5.11
CP9	5.80	4.95
CP10	5.80	4.54
CP11	5.80	4.36
CP12	4.80	4.16
CP13	3.80	2.80

- HALF ROUND, U, AND STEPPED - CHANNELS**
- ALL DIMENSIONS ARE IN MILLIMETRES
 - CONCRETE SURFACE FINISHING SHALL BE CLASS U2 OR F2 AS APPROPRIATE
 - FOR HALF ROUND AND U - CHANNEL, SPACING OF EXPANSION JOINT IN CHANNELS, BERMS AND APRON TO BE 10m MAXIMUM. FOR STEPPED CHANNELS, EXPANSION JOINTS TO BE PROVIDED AT A MAXIMUM SPACING OF 10m.
 - DIMENSIONS FOR HALF ROUND AND U-CHANNELS SEE TABLE 1.
 - THE COVER FOR U-CHANNELS AND CATCHPIT SHALL COMPLY WITH CEDD'S STANDARD DRAWINGS NO. C2405 TO C2407 AND C2412.
 - ALL PROPOSED U-CHANNELS SHALL BE COVERED WITH GRATING

TABLE 1 : DIMENSION OF U-CHANNEL AND HALF-ROUND CHANNEL

NORMAL SIZE H	T	B	REINFORCING
<300	100	100	NIL
375 - 675	150	150	NIL
750 - 900	175	175	A252 MESH PLACED CENTRALLY

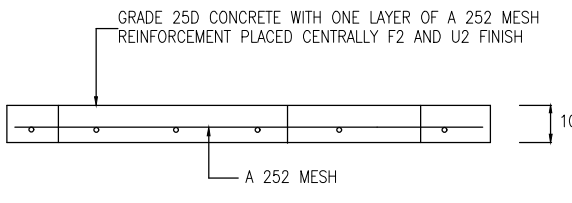
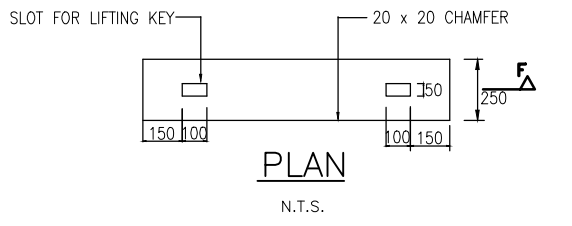

PRECAST CONCRETE COVERS FOR CATCHPIT

REV	DESCRIPTION	CHECKED	APPROVED	DATE

PROJECT TITLE:
STORMWATER DRAINAGE PROPOSAL
LOT 1819, 1820, 1821, 1822(PART) AND 1905(PART)
IN D.D.107 KAM TIN, YUEN LONG, N.T.

DRAWING TITLE:
DRAINAGE PROPOSAL PLAN
AND TYPICAL DETAILS

SCALE :	N.T.S.	CAD FILE :	CAD_DEF
DRAWN :	RY	DRAWING NO. :	SDP001
S.D :	RY		
DESIGNED :	RC		
CHECKED :	AY		

B.D. REF. NO.:

Appendix B
Surface Drainage Design

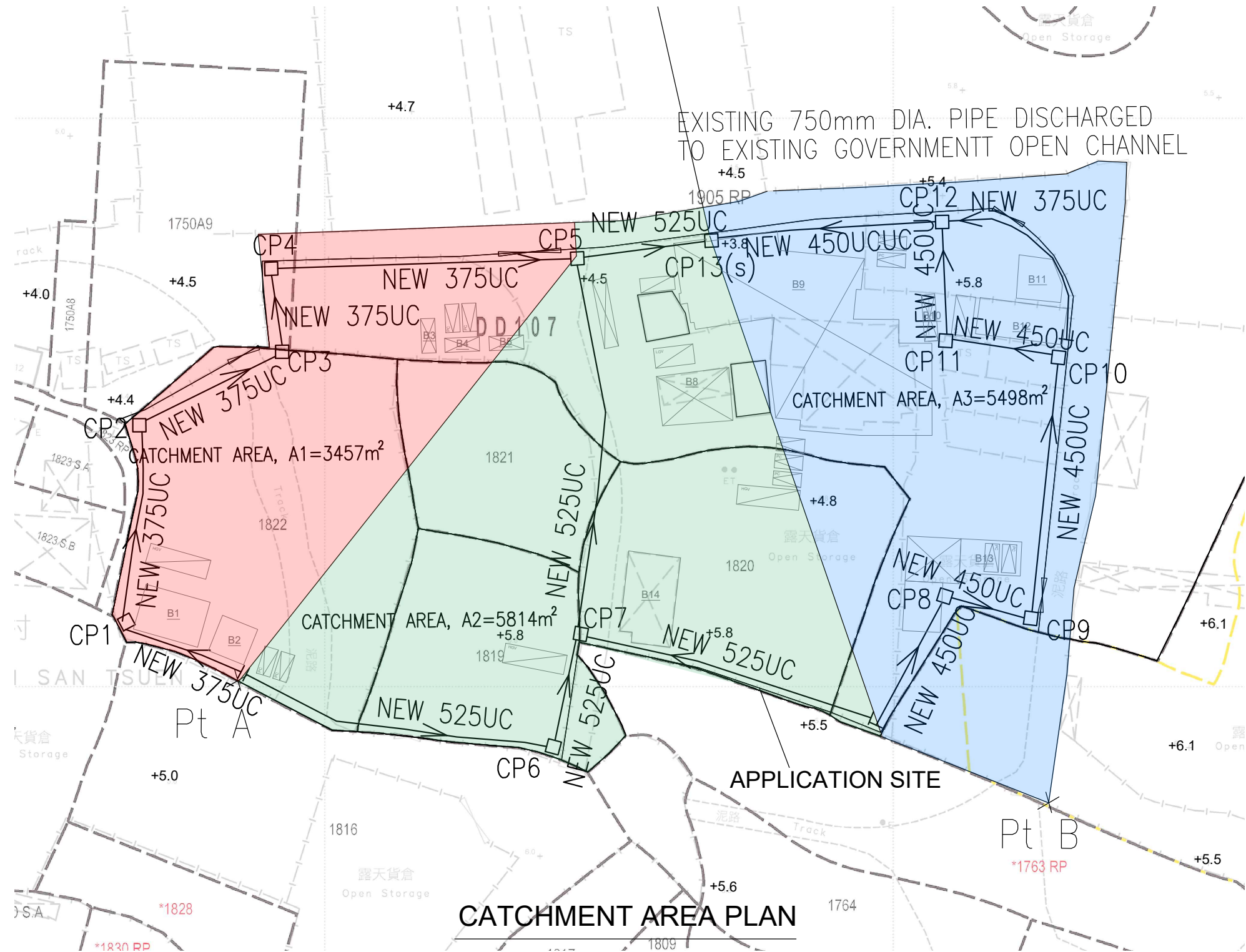

CATCHMENT AREA PLAN

Drainage Design at lot 1819, 1820, 1821,
 Project No.: 1822(PART) AND 1905(PART) 107 Date: 23-Mar-26
 Prepared by: Ray Cheng

Check for the drainage capacity of proposed 375UC

Catchment area, A1 = 3457 m² Assume k = 0.95 for paved surface

Use Rational Method from Geo-Manual

$$Q = kiA/3600$$

where,

Q = Maximum runoff (lit/sec)
 k = Runoff coefficient
 i = Design mean intensity of rainfall (mm/hr)
 A = Total catchment area (m²)

Longest distance from summit point to outlet, CP5 (Ld) = 157.00 m
 Shortest distance from summit point to outlet, CP5 (Ls) = 97.00 m

Elevation of remote point (Pt A) = 5.80 mPD
 Elevation of outlet point (CP5) = 3.850 mPD

Average fall, H = $(z_1 - z_2) / L_s \times 100$
 = 2.01 m per 100m

$$T_c = 0.14465 \times L_d / (H^{0.2} \times A^{0.1})$$

= 8.74 min

Assume a 1 in 50 year design rainfall return period for rural area
 From SDM Corrigendum No. 1/2024

i = 200 mm/hr
 Q = $kiA/60 \times 1.16$ lit/min
 12699 lit/min

rainfall increase

From TGN 43A1
 For proposed 375 UC with 1 in 100 gradient

Maximum capacity = 16000 lit/min > 12699 o.k.
 The corresponding velocity = 1.95 m/s < 4 o.k.

Drainage Design at lot 1819, 1820, 1821,
 Project No.: 1822(PART) AND 1905(PART) 107 Date: 23-Mar-26
 Prepared by: Ray Cheng

Check for the drainage capacity of proposed 525UC

Catchment area,	A1	=	3457	m ²	
	A2	=	5814	m ²	Assume k = 0.95 for paved surface
Ttotal Catchment Area, A1+A2		=	9271	m ²	

Use Rational Method from Geo-Manual

$$Q = kiA/3600$$

where,

- Q = Maximum runoff (lit/sec)
- k = Runoff coefficient
- i = Design mean intensity of rainfall (mm/hr)
- A = Total catchment area (m²)

Longest distance from summit point to outlet, CP13(s) (Ld) = 172.00 m
 Shortest distance from summit point to outlet, CP13(s) (Ls) = 117.00 m

Elevation of remote point (Pt A) = 5.80 mPD
 Elevation of outlet point (CP13(s)) = 2.800 mPD

Average fall, H = (z₁-z₂)/L_s x 100
 = 2.56 m per 100m

$$T_c = 0.14465 \times L_d / (H^{0.2} \times A^{0.1})$$

$$= 8.27 \text{ min}$$

Assume a 1 in 50 year design rainfall return period for rural area
 From SDM Corrigendum No. 1/2024

i	=	200	mm/hr	rainfall increase
Q	=	kiA/60	x 1.16	
		34055	lit/min	

From TGN 43A1
 For proposed 525 UC with 1 in 100 gradient

Maximum capacity	=	39000	lit/min	>	34055	o.k.
The corresponding velocity	=	2.50	m/s	<	4	o.k.

Drainage Design at lot 1819, 1820, 1821,
 Project No.: 1822(PART) AND 1905(PART) 107 Date: 23-Mar-26
 Prepared by: Ray Cheng

Check for the drainage capacity of proposed 450C

Catchment area, A3 = 5498 m² Assume k = 0.95 for paved surface

Use Rational Method from Geo-Manual

$$Q = kiA/3600$$

where,

Q = Maximum runoff (lit/sec)
 k = Runoff coefficient
 i = Design mean intensity of rainfall (mm/hr)
 A = Total catchment area (m²)

Longest distance from summit point to outlet, CP13(s) (Ld) = 167.00 m
 Shortest distance from summit point to outlet, CP13(s) (Ls) = 118.00 m

Elevation of remote point (Pt B) = 5.50 mPD
 Elevation of outlet point (CP13(s)) = 2.800 mPD

Average fall, H = $(z_1 - z_2) / L_s \times 100$
 = 2.29 m per 100m

$$T_c = 0.14465 \times L_d / (H^{0.2} \times A^{0.1})$$

$$= 8.65 \text{ min}$$

Assume a 1 in 50 year design rainfall return period for rural area
 From SDM Corrigendum No. 1/2024

i = 200 mm/hr
 Q = $kiA/60 \times 1.16$ lit/min
 20196 lit/min

rainfall increase

From TGN 43A1
 For proposed 450 UC with 1 in 100 gradient

Maximum capacity = 25000 lit/min > 20196 o.k.
 The corresponding velocity = 2.25 m/s < 4 o.k.

Drainage Design at lot 1819, 1820, 1821,
 Project No.: 1822(PART) AND 1905(PART) 107 Date: 23-Mar-26
 Prepared by: Ray Cheng

Check for the drainage capacity of existing 750mm dia. pipe

Catchment area,	A1	=	3457	m ²	
	A2	=	5814	m ²	Assume k = 0.95 for paved surface
	A3	=	5498	m ²	
Total Catchment Area, A1+A2+A3		=	14769	m ²	

Use Rational Method from Geo-Manual

$$Q = kiA/3600$$

where,

- Q = Maximum runoff (lit/sec)
- k = Runoff coefficient
- i = Design mean intensity of rainfall (mm/hr)
- A = Total catchment area (m²)

Longest distance from summit point to outlet, CP13s) (Ld) = 172.00 m
 Shortest distance from summit point to outlet, CP13(s) (Ls) = 117.00 m

Elevation of remote point (Pt A) = 5.80 mPD
 Elevation of outlet point (CP13(s)) = 2.800 mPD

Average fall, H = $(z_1 - z_2) / L_s \times 100$
 = 2.56 m per 100m

$$T_c = 0.14465 \times L_d / (H^{0.2} \times A^{0.1})$$

$$= 7.89 \text{ min}$$

Assume a 1 in 50 year design rainfall return period for rural area
 From SDM Corrigendum No. 1/2024

i = 205 mm/hr — rainfall increase
 Q = $kiA/60 \times 1.16$
 = 55608 lit/min

The capacity of the existing 750mm dia. pipe = 74160 lit/min > 55608 o.k.

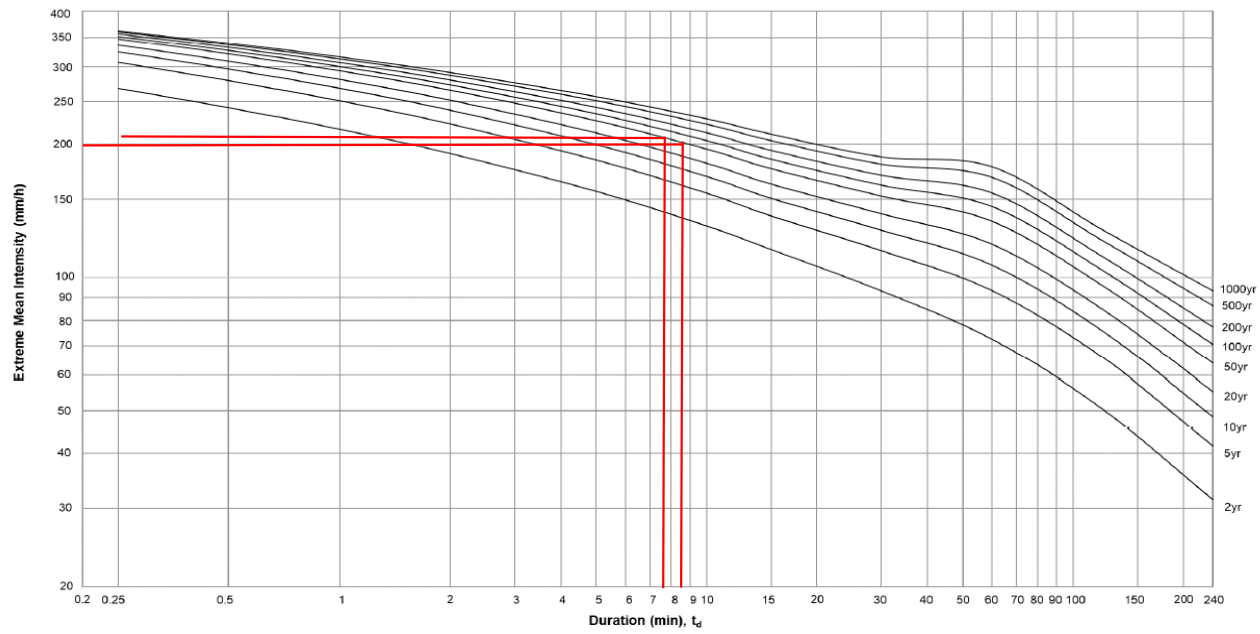
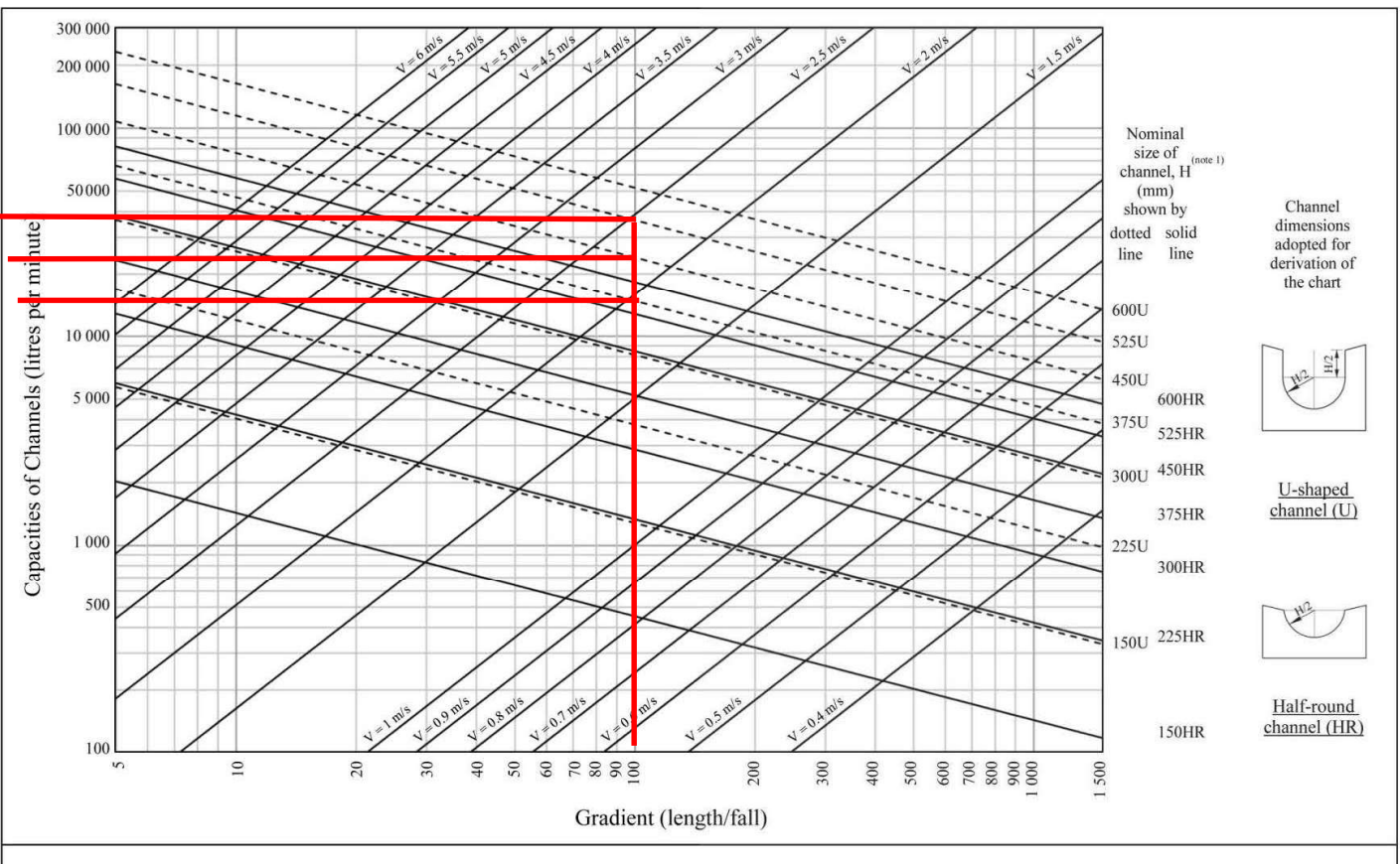

Figure 4a – Intensity-Duration-Frequency Curves of HKO Headquarters
(for durations not exceeding 4 hours)

**GEO Technical Guidance Note No. 43 (TGN 43)
Guidelines on Hydraulic Design of U-shaped and Half-round Channel Slopes**

Issue No.: 1 | Revision: - | Date: 05/06/2014 | Page: 3 of 3



continued

ie hydraulic gradient =
1 in 250 to 1 in 10velocities in m/s
discharges in m³/s

The capacity of 750mm dia. pipe = $1.236 \times 1000 \times 60 = 74,160$ lit/min

Gradient	Pipe diameters in mm.											
	350	375	400	450	500	525	600	675	700	750	800	825
0.00400 1/ 250	1.091	1.140	1.187	1.280	1.368	1.410	1.534	1.651	1.689	1.764	1.836	1.871
	0.105	0.126	0.149	0.203	0.269	0.305	0.434	0.591	0.650	0.779	0.923	1.000
0.00420 1/ 238	1.118	1.168	1.217	1.311	1.402	1.446	1.572	1.692	1.731	1.808	1.882	1.918
	0.108	0.129	0.153	0.209	0.275	0.313	0.444	0.606	0.666	0.799	0.946	1.025
0.00440 1/ 227	1.145	1.196	1.246	1.343	1.435	1.480	1.609	1.733	1.772	1.850	1.926	1.963
	0.110	0.132	0.157	0.214	0.282	0.320	0.455	0.620	0.682	0.817	0.968	1.050
0.00460 1/ 217	1.171	1.223	1.274	1.373	1.468	1.513	1.646	1.772	1.813	1.892	1.970	2.008
	0.113	0.135	0.160	0.218	0.288	0.328	0.465	0.634	0.698	0.836	0.990	1.073
0.00480 1/ 208	1.196	1.250	1.302	1.403	1.499	1.546	1.682	1.810	1.852	1.933	2.013	2.051
	0.115	0.138	0.164	0.223	0.294	0.335	0.475	0.648	0.713	0.854	1.012	1.097
0.00500 1/ 200	1.221	1.276	1.329	1.432	1.531	1.578	1.717	1.848	1.890	1.973	2.054	2.094
	0.117	0.141	0.167	0.228	0.301	0.342	0.485	0.661	0.727	0.872	1.033	1.119
0.00550 1/ 182	1.281	1.339	1.395	1.503	1.606	1.656	1.801	1.939	1.983	2.070	2.155	2.197
	0.123	0.148	0.175	0.239	0.315	0.359	0.509	0.694	0.763	0.915	1.083	1.174
0.00600 1/ 167	1.339	1.399	1.457	1.570	1.678	1.730	1.882	2.026	2.072	2.163	2.252	2.295
	0.129	0.155	0.183	0.250	0.330	0.375	0.532	0.725	0.797	0.956	1.132	1.227
0.00650 1/ 154	1.394	1.457	1.518	1.635	1.747	1.802	1.959	2.109	2.157	2.252	2.344	2.390
	0.134	0.161	0.191	0.260	0.343	0.390	0.554	0.755	0.830	0.995	1.178	1.277
0.00700 1/ 143	1.447	1.512	1.575	1.697	1.814	1.870	2.034	2.189	2.239	2.338	2.433	2.480
	0.139	0.167	0.198	0.270	0.356	0.405	0.575	0.783	0.862	1.033	1.223	1.326
0.00750 1/ 133	1.499	1.566	1.631	1.757	1.878	1.936	2.106	2.266	2.318	2.420	2.519	2.568
	0.144	0.173	0.205	0.279	0.369	0.419	0.595	0.811	0.892	1.069	1.266	1.373
0.00800 1/ 125	1.548	1.618	1.685	1.815	1.940	2.000	2.175	2.341	2.395	2.500	2.602	2.653
	0.149	0.179	0.212	0.289	0.381	0.433	0.615	0.838	0.922	1.105	1.308	1.418
0.00850 1/ 118	1.596	1.668	1.737	1.872	2.000	2.062	2.243	2.414	2.469	2.577	2.683	2.735
	0.154	0.184	0.218	0.298	0.393	0.446	0.634	0.864	0.950	1.139	1.349	1.462
0.00900 1/ 111	1.643	1.717	1.788	1.926	2.059	2.123	2.308	2.484	2.541	2.653	2.761	2.814
	0.158	0.190	0.225	0.306	0.404	0.459	0.653	0.889	0.978	1.172	1.388	1.504
0.00950 1/ 105	1.688	1.764	1.838	1.980	2.115	2.181	2.372	2.553	2.611	2.726	2.837	2.892
	0.162	0.195	0.231	0.315	0.415	0.472	0.671	0.913	1.005	1.204	1.426	1.546
0.01000 1/ 100	1.733	1.810	1.886	2.031	2.171	2.238	2.434	2.619	2.679	2.797	2.911	2.967
	0.167	0.200	0.237	0.323	0.426	0.485	0.688	0.937	1.031	1.236	1.463	1.586
0.01100	1.818	1.899	1.978	2.131	2.277	2.348	2.553	2.748	2.811	2.934	3.054	3.113