

Annex H Revised Traffic Impact Assessment

Document Status Control Record

**Application for Amendment of Plan under Section 12A
for the Town Planning Ordinance (Cap. 131) for Mixed Use Development
at Lot 796 and 1008RP in D.D. 77 and Adjoining Government Land in
Ping Che, Ta Kwu Ling, New Territories**

Traffic Impact Assessment Report

Originating Organisation: LLA Consultancy Limited Unit 610, 6/F Island Place Tower 510 King's Road North Point, Hong Kong	Prepared by: SKL	SKL	Date: 26 March 2024
	Approved by: SLN	SLN	Date: 26 March 2024
	Revision No.: -		Date of Issue: 26 March 2024

Note: © - LLA Consultancy Limited. All rights reserved. Except for the internal use by the client for whom this document is prepared by LLA Consultancy Limited. No part of this document, which contains valuable trade secrets of a confidential nature to LLA Consultancy Limited may be (1) reproduced, stored in a retrieval system, or transmitted in any format or by any means, electronic, mechanical, photocopying, recording or otherwise; or (2) disclosed to any third party, without the prior consent of LLA Consultancy Limited.

1 INTRODUCTION

1.1 Background

1.1.1 The subject site (hereinafter referred to “the Application Site”) is located at Lot 796 & 1008RP at D.D.77 and adjoining government land in Ping Che. The location of the Application Site is shown in **Figure 1.1**.

1.1.2 The applicant proposed to develop the Application Site into a mixed use development for residential and commercial uses. LLA Consultancy Limited was commissioned to undertake a traffic impact assessment study for the proposal. This report presents the findings of the study.

1.2 Objectives

1.2.1 The objectives of the study are as follows:

- to review the existing traffic conditions in the vicinity of the Application Site;
- to estimate the traffic generation and attraction of the proposed development;
- to project the future traffic situations in the surrounding road network;
- to appraise the potential traffic impact of the proposed development and to consider road improvement proposals, if required; and
- to recommend the internal transport facilities for the proposed development.

2 THE PROPOSED DEVELOPMENT

2.1 The Application Site

2.1.1 As shown in **Figure 1.1**, the Application Site is located in Ping Che with a total site area of about 17,822 m².

2.2 Development Schedule

2.2.1 **Table 2.1** summarises the development parameters of the proposed development.

Table 2.1 Proposed Development Schedule

Item		Parameters
Application Site Area		17,822 m ²
Proposed Plot Ratio		7.0
Domestic Plot Ratio		Not more than 5.9
Non-domestic Plot Ratio		Not more than 1.1
Domestic Use		
Gross Floor Area		About 105,145 m ²
No. of blocks		5
Total Number of Residential Unit		2,205
Average Flat Size		47.7 m ²
Non-domestic Use		
Gross Floor Area	Retail	2,400 m ²
	Office	About 11,500 m ²
	Hotel	About 5,703 m ²
No. of blocks		1
No. of hotel rooms		70 rooms
Day Care Centre for the Elderly (DE)		60 places
Child Care Centre (CCC)		100 places

3 EXISTING TRAFFIC SITUATION

3.1 Existing Road Network

- 3.1.1 At present, the Application Site is served by a local access road located along the eastern side of the Application Site, which also serves other village developments in the area.
- 3.1.2 Ping Che Road is a single two-lane rural road. Its northern end and southern end connect to Lin Ma Hang Road and Sha Tau Kok Road – Ma Mei Ha, respectively.
- 3.1.3 Sha Tau Kok Road – Ma Mei Ha is connecting between Lau Shui Heung Road and Wo Keng Shan Road. The section between Lau Shui Heung Road and Ping Che Road is a dual two carriageway while the section between Ping Che Road and Wo Keng Shan Road is a single two carriageway, except the local widening near the two junctions.

3.2 Traffic Count Surveys

3.2.1 In order to assess the existing traffic conditions, traffic count surveys were carried out on 15 June 2023 (Thursday) during AM and PM peak periods at 07:30 to 09:30 and 17:00 to 19:00 at key junctions in the vicinity of the Application Site. The locations of the surveyed junctions are presented in **Figure 3.1**.

- Sha Tau Kok Road / Heung Yuen Wai Highway
- Sha Tau Kok Road / Ping Che Road
- Sha Tau Kok Road / Lau Shui Heung Road
- Ping Che Road / Ng Chow Road
- Sha Tau Kok Road / Lung Ma Road

3.2.2 The morning and the evening peak hours identified are 08:00 – 09:00 (AM Peak) and 17:30 – 18:30 (PM Peak). The surveyed 2023 traffic flows are presented in **Figure 3.2**.

3.3 Existing Junction Capacity Assessment

3.3.1 Based on the observed traffic flows, the performance of the key junction is assessed. The results are summarized and presented in **Table 3.1**. The detailed calculation sheets are attached in **Appendix A**.

Table 3.1 Existing Junction Performance

No.	Junction Location	Type/ Capacity Index ⁽¹⁾	AM Peak	PM Peak
J1	Sha Tau Kok Road / Heung Yuen Wai Highway	Roundabout/DFC	0.44	0.39
J2	Sha Tau Kok Road / Ping Che Road	Roundabout/DFC	0.42	0.40
J3	Sha Tau Kok Road / Lau Shui Heung Road	Roundabout/DFC	0.54	0.58
J4	Ping Che Road / Ng Chow Road	Priority/DFC	0.19	0.11
J5	Sha Tau Kok Road / Lung Ma Road	Roundabout/DFC	0.46	0.43

Note: (1) DFC = Design Flow to Capacity ratio for priority junction.

3.3.2 From **Table 3.1**, it is noted that all junctions are operating satisfactorily during the existing AM and PM peak hours.

3.4 Existing Public Transport Facilities

3.4.1 1 franchised bus route and 1 green minibus route are operating along Ping Che Road outside the Application Site. **Table 3.2** shows the existing franchised bus/minibus route operating in the vicinity of the Application Site.

Table 3.2 Existing Road-Based Public Transport Services

Route No.	Terminal Points	Frequency
Franchised Bus		
79K	Ta Kwu Ling (Tsung Yuen Ha) – Sheung Shui	15 – 30
Green Minibus		
52K	Fanling – Ping Che	4 – 10

3.5 Existing Link Capacity Assessment

3.5.1 The Volume to Capacity (V/C) Ratios of Sha Tau Kok Road and Ping Che Road were assessed and the results are presented in **Table 3.3**.

Table 3.3 Link Capacity Assessments

Direction	Capacity (pcu/hr) ⁽¹⁾	Traffic Flow (pcu/hr)		V/C Ratio	
		AM	PM	AM	PM
Sha Tau Kok Road (between Ping Che Road and Heung Yuen Wai Highway)	2,250 ⁽²⁾	1,362	1,342	0.61	0.60
Sha Tau Kok Road (between Lau Shui Heung Road and Ping Che Road)	6,300 ⁽²⁾	1,704	1,744	0.27	0.28
Ping Che Road (between Sha Tau Kok Road and Hung Leng North Road)	1,910 ⁽²⁾	1,260	1,260	0.66	0.66

Note: (1) Capacity refers to TPDM Vol.2 Ch. 2.4. A factor of 1.25 is adopted to convert the capacity from veh/hr to pcu/hr.
(2) The capacity of each carriageway is reduced by 10% due to the high proportion of heavy vehicles.

3.5.2 As shown in **Table 3.3**, the concerned road sections are operating with spare capacity during both AM and PM peak hours.

4 FUTURE TRAFFIC SITUATION

4.1 Design Year

4.1.1 The proposed development will be completed in 2032. Therefore, the design year for the following traffic impact assessment will be 2035, i.e. 3 years after the completion.

4.2 Traffic Generation of the Proposed Development

4.2.1 In order to examine the traffic impact of the proposed development, traffic generated/ attracted by the proposed development should be estimated based on the development parameters as listed in **Table 2.1** and the trip rates documented in TPDM Volume 1 Chapter 3 – Transport Considerations of Town Plans.

4.2.2 As there is no established trip rates published in Transport Planning and Design Manual (TPDM) or other relevant guidelines for day care centre for the elderly and child care centre, trip generation surveys at existing day care centre for the elderly and child care centre, were arranged to collect trip rates of carpark. The trip generation survey was conducted on 15 June 2023 (Thursday) during the peak hour period from 07:30 to 09:30 and 17:00 to 19:00. The survey results and the derived trip rates are presented in **Table 4.1**.

Table 4.1 Survey Results at the Existing Buildings

Building Name (Location)	Unit / Content	AM Peak			PM Peak		
		Gen.	Att.	2-way	Gen.	Att.	2-way
Traffic Generation of Existing Day Care Centre for the Elderly (pcu/hr)							
Fung Kai Care & Attention Home for the Elderly-Day Care Centre for the Elderly (Fung Kai Social Service Complex, 22 Tin Ping Road, Sheung Shui, N.T.)	80 places	3	4	7	3	3	6
Traffic Generation of Existing Child Care Centre (pcu/hr)							
Hong Kong Society for the Protection of Children Esther Lee Day Creche (Hong Ming House, Wah Ming Estate, Fanling, N.T.)	51 places	2	2	4	2	2	4
Derived Trip Rates (pcu/hr/place)							
Day Care Centre for the Elderly		0.3750	0.5000	-	0.3750	0.3750	-
Child Care Centre		0.3922	0.3922	-	0.3922	0.3922	-

Note: Gen. – Generation; Att. – Attraction.

4.2.3 Based on the above, the traffic generation of the proposed development is estimated and presented in **Table 4.2**.

Table 4.2 Traffic Generations of the Proposed Development

Proposed Use	Unit / Content	AM Peak Hour			PM Peak Hour		
		Gen.	Att.	Total	Gen.	Att.	Total
Adopted Trip Rates⁽¹⁾							
Residential – 60m ²	pcu/hr/flat	0.1021	0.0709	-	0.0415	0.0464	-
Retail	pcu/hr/100m ² GFA	0.3307	0.3342	-	0.3839	0.4504	-
Office	pcu/hr/100m ² GFA	0.2361	0.3257	-	0.1928	0.1510	-
Hotel	pcu/hr/guestroom	0.1814	0.2082	-	0.1697	0.2183	-
Day Care Centre for the Elderly	pcu/hr/place	0.3750	0.5000	-	0.3750	0.3750	-
Child Care Centre	pcu/hr/place	0.3922	0.3922	-	0.3922	0.3922	-
Traffic Generation/Attraction							
Residential	2,205 flats	226	157	383	92	103	195
Retail	2,400 m ² GFA	8	9	17	10	11	21
Office	11,503 m ² GFA	28	38	66	23	18	41
Hotel	70 guestrooms	13	15	28	12	16	28
Day Care Centre for the Elderly	60 places	10	11	21	10	11	21
Child Care Centre	100 places	3	3	6	3	3	6
Total		282	226	508	144	155	299

Notes: (1) Upper limit trip rates from TPDM are adopted.

4.2.4 As shown in **Table 4.2**, the proposed development would generate a two-way traffic flow of **508** pcu/hr in the AM peak and **299** pcu/hr in the PM peak. The corresponding traffic distribution patterns are estimated and presented in **Figure 4.1**.

4.3 Traffic Generation of the Planned/Committed Developments

4.3.1 To estimate the future traffic flows, updated information has been obtained from available information regarding the planned and approved developments in the vicinity of the study area. Details of these developments are given in **Table 4.3**.

Table 4.3 Details of Planned and Approved Developments

Site	Location	Use	Content
S1	Lots 825, 834 and 836 in D.D. 77 and adjoining government land, Ping Che (Planning Application No. A/NE-TKL/608)	Industrial	1,871 m ² GFA
S2	Queen's Hill Development – Site 1	Public Rental Housing	8,840 flats
		Subsidized Sale Flat	3,260 flats
		Primary School	2 (30 classrooms)
		Kindergarten	3 (2 with 30 classrooms and 1 with 7 classrooms)
		Welfare Facilities	8,140 m ² GFA
		Retail	12,500 m ² GFA
	Queen's Hill Development – Site 2	Private Housing	2,670 flats
	Queen's Hill Development – Site 3	International School	1
	Queen's Hill Development – Others	Primary School	1
		Community Facilities	5,000 m ² GFA

4.3.2 Reference was also made to the latest set of traffic generation and attraction rates published by TD for the estimation of the traffic generated by these developments. The traffic generation/attractions by these nearby developments are taken into account in the following assessment.

4.4 Future Traffic Flows

4.4.1 Reference was made to the 2017 to 2021 Annual Traffic Census Reports published by the Transport Department. The traffic data recorded at counting stations in the vicinity of the Phase III Development Site are shown in **Table 4.4**.

Table 4.4 Annual Traffic Census Data

Stn. No.	Road Section			AADT ⁽¹⁾					Avg. Growth%
	Road	From	To	2017	2018	2019	2020	2021	
5660	Sha Tau Kok Rd	On Kui St	Ping Che Rd	33,050	33,870 (2.5%)	33,630 (-0.7%)	23,740 (-29.4%)	22,980 (-3.2%)	-8.7%
5860	Sha Tau Kok Rd	Ping Che Rd	Shun Lung St	6,460	6,620 (2.5%)	6,570 (-0.8%)	6,300 (-4.1%)	5,970 (-5.2%)	-2.0%
6653	Ping Che Rd	Sha Tau Kok Rd	Lin Ma Hang Rd	11,360	11,430 (0.6%)	11,820 (3.4%)	11,030 (-6.7%)	11,870 (7.6%)	1.1%
Total				50,870	51,920 (2.1%)	52,020 (0.2%)	41,070 (-21%)	40,820 (-0.6%)	-5.4%

Note: (1) Figures in bracket indicated the % increase/decrease between two years.

4.4.2 As shown in **Table 4.4**, the average annual growth rate with reference to the AADT is -5.4% between 2017 to 2021. For conservative assessment purpose, a nominal growth rate of +1.0% will be adopted in the following assessments.

4.5 2035 Reference and Design Traffic Flows

4.5.1 The 2035 Reference Flows, i.e. the traffic flows in the local road without the proposed development, were estimated based on the following equation.

$$2035 \text{ Reference Flows} = 2023 \text{ Existing Flows} \times (1+1.0\%)^{12} + \text{Traffic Generated by Approved/Planned Development}$$

4.5.2 The 2035 Design Flows, i.e. the traffic flows in the local road network with the proposed development, were estimated based on the following equation:

$$2035 \text{ Design Flows} = 2035 \text{ Reference Flows} + \text{Additional Traffic Induced by the Proposed Development}$$

4.5.3 The 2035 Reference and Design Flows are shown in **Figures 4.2 and 4.3**, respectively.

4.6 Junction Capacity Assessment

4.6.1 Junction capacity analysis is carried out for the assessment year 2035. The assessment results are shown in **Table 4.5** and the detailed calculation sheets are attached in **Appendix B**.

Table 4.5 Future Junction Performance

Ref.	Junction Location	Type/ Index ⁽¹⁾	2035 Reference		2035 Design	
			AM Peak	PM Peak	AM Peak	PM Peak
J1	Sha Tau Kok Road / Heung Yuen Wai Highway	Roundabout/DFC	0.52	0.45	0.62	0.51
J2	Sha Tau Kok Road / Ping Che Road	Roundabout/DFC	0.50	0.47	0.68	0.57
J3	Sha Tau Kok Road / Lau Shui Heung Road	Roundabout/DFC	0.64	0.67	0.65	0.68
J4	Ping Che Road / Ng Chow Road	Priority/DFC	0.26	0.17	0.85	0.47
J5	Sha Tau Kok Road / Lung Ma Road	Roundabout/DFC	0.76	0.75	0.77	0.76

Note: (1) DFC = Design Flow to Capacity ratio for priority junction and roundabout.

4.6.2 As shown in **Table 4.5**, all concerned junctions will operate with capacities in future scenarios. Therefore, the additional traffic generated by the proposed development is not anticipated to induce significant traffic impact onto the adjacent junctions.

4.6.3 For J4 – Ping Che Road / Ng Chow Road, the section of the local road to the south of Ping Che Road, which is along the subject site boundary, will be upgraded to a 7.3m carriageway with local widening to 10.3m near it's junction with Ping Che Road. A short section of Ping Che Road will be widened to provide a right-turn pocket at this junction as well. The schematic junction layout is shown in **Figure 4.4**.

4.7 Link Capacity Assessment

4.7.1 The V/C Ratios of Sha Tau Kok Road and Ping Che Road were assessed and the results are presented in **Table 4.6**.

Table 4.6 Year 2035 Link Capacity Assessments

Direction	Capacity (pcu/hr) ⁽¹⁾	Traffic Flow (pcu/hr)		V/C Ratio	
		AM	PM	AM	PM
2035 Reference Scenario					
Sha Tau Kok Road (between Ping Che Road and Heung Yuen Wai Highway)	2,250 ⁽²⁾	1,620	1,577	0.72	0.70
Sha Tau Kok Road (between Lau Shui Heung Road and Ping Che Road)	6,300 ⁽²⁾	1,990	2,015	0.32	0.32
Ping Che Road (between Sha Tau Kok Road and Hung Leng North Road)	1,910 ⁽²⁾	1,444	1,404	0.76	0.74
2035 Design Scenario					
Sha Tau Kok Road (between Ping Che Road and Heung Yuen Wai Highway)	2,250 ⁽²⁾	1,899	1,762	0.84	0.78
Sha Tau Kok Road (between Lau Shui Heung Road and Ping Che Road)	6,300 ⁽²⁾	2,025	2,038	0.32	0.32
Ping Che Road (between Sha Tau Kok Road and Hung Leng North Road)	1,910 ⁽²⁾	1,758	1,612	0.92	0.84

Note: (1) Capacity refers to TPDM Vol.2 Ch. 2.4. A factor of 1.25 is adopted to convert the capacity from veh/hr to pcu/hr.
(2) The capacity of each carriageway is reduced by 10% due to the high proportion of heavy vehicles.

4.7.2 As shown in **Table 4.5**, Sha Tau Kok Road and Ping Che Road will operate with capacity with V/Cs under 0.92 during both AM and PM peak hours in all scenarios.

5 PROPOSED TRANSPORT FACILITIES PROVISIONS

5.1 Vehicular Access Arrangement and Public Transport Terminus

- 5.1.1 At present, the Application Site is served by a local access road located along the eastern side of the Application Site, which also serves other village developments in the area. Under the proposed development scheme, the local access road will be upgraded to a standard 7.3m single carriageway with footpaths on both sides.
- 5.1.2 Two vehicular accesses are provided at the local access road to serve the development. One access will be located to the southern side of the Application Site to serve the residential blocks while another access will be located at the mid-way along the access road to serve mainly the commercial building and as the secondary access for the residential blocks.
- 5.1.3 Taking into consideration the future planning at Ping Che area and the relatively large area of the Application Site, a public transport terminus (PTT) is proposed at the northern part of the Application Site along Ping Che Road. The PTT will comprise of a double width bus bay and a GMB bay. The ingress point is located at the upgraded access road and the egress point is located at Ping Che Road to provide better circulations within the PTT.

5.2 Internal Transport Facilities

- 5.2.1 The internal transport facilities for the proposed development uses will be provided in accordance with the Hong Kong Planning Standards and Guidelines (HKPSG). The required provisions for the proposed development are shown in **Table 5.1**.

Table 5.1 Parking Requirement for Proposed Development

Development Type		HKPSG Requirements					HKPSG Required Nos.	Proposed No.
Car parking	Residential	Parking Requirements = GPS x R1 x R2 x R3 where GPS = 1 space per 4 – 7 units					341 – 596	596
		Flat Size (FS)	No. of Unit	R1	R2	R3		
		40 m ² < FS <= 70 m ²	2,205	1.2	1.00	0.9		
		<u>For Visitors:</u> 5 visitor spaces per block						
	Retail (2,400 m ²)	1 car parking space per 150 – 300 m ² GFA					8 – 16	16
	Office (11,503 m ²)	1 car parking space per 150 – 200 m ² GFA					58 – 77	77
	Hotel (70 rooms)	1 car parking space per 100 rooms					1	1
	DE	No specific requirements under HKPSG					–	5
	CCC	No specific requirements under HKPSG					–	5
TOTAL CAR PARKING						433 – 715	725	
Loading /unloading	Residential	Minimum of 1 loading / unloading bay for goods vehicles within the site for every 800 flats or part thereof, subject to a minimum of 1 bay for each housing block					5	5

Development Type		HKPSG Requirements	HKPSG Required Nos.	Proposed No.
	Retail	1 loading/unloading bay for goods vehicles for every 800 – 1,200m ² or part thereof, GFA	2 – 3	3
	Office	1 loading/unloading bay for goods vehicles for every 2,000 – 3,000m ² or part thereof, GFA	4 – 6	6
	Hotel	0.5 – 1 loading/unloading bay per 100 rooms	1	1
	DE	No specific requirements under HKPSG	–	2
	CCC	No specific requirements under HKPSG	–	1
TOTAL LOADING/UNLOADING			12 – 15	18
Motorcycle Parking	Residential	1 space per 100 – 150 flats	15 – 23	23
	Retail, Office and Hotel	10% of Total Provision of Private Car Spaces (94 spaces)	10	10
TOTAL MOTORCYCLE PARKING			25 – 33	33
Lay-by for Taxi and Private Car	Hotel	2 lay-bys for less than 300 rooms	2	2
TOTAL LAY-BY FOR TAXI AND PRIVATE CAR			2	2
Lay-by for Single-deck Tour Bus	Hotel	1 lay-by for less than 300 rooms	1	1
TOTAL LAY-BY FOR SINGLE-DECK TOUR BUS			1	1

5.2.2 As shown in **Table 5.1**, 725 private car parking spaces (including 6 no. of parking space for disabled users), 18 goods vehicle loading / unloading bays, 33 motorcycle parking spaces, 2 lay-bys for taxi and private car and 1 lay-by for single-deck tour bus will be provided to fulfil the HKPSG requirements. Preliminary layouts of car parking and loading/unloading facilities of the proposed development are enclosed in **Appendix C**.

5.3 Swept path Analysis

5.3.1 To ensure smooth manoeuvring of the parking area, swept path analysis was conducted to demonstrate that adequate space is provided for the vehicles for manoeuvring and presented in **Appendix C**.

6 SUMMARY AND CONCLUSION

6.1 Summary

- 6.1.1 The Application Site is located at Lot 796 & 1008RP at D.D.77 and adjoining government land in Ping Che and the Applicant proposed to develop the Application Site into a mixed use development for residential and commercial uses.
- 6.1.2 A traffic count survey was carried out on 15 June 2023 (Thursday) during the peak hour period from 07:30 to 9:30 and 17:00 to 19:00 at the identified key junctions, and the AM and PM peak hours were found to be 08:00 – 09:00 and 17:30 – 18:30, respectively. The capacity of the key junctions and road links in the vicinity of the Application Site was analysed and they are operating satisfactorily.
- 6.1.3 The proposed development would generate two-way traffic flows of 508 pcu/hr in the AM peak hour and 299 pcu/hr in the PM peak hour. These two-way trips will be adopted for the subsequent assessments. By assigning the additional development traffic to the 2035 Reference Flows, the 2035 Design Flows were obtained.
- 6.1.4 Junction and link capacity assessments were carried out at the key junctions in the vicinity for the year 2035. The results have indicated that all junctions and road links will operate satisfactorily for both reference and design scenarios. Therefore, it is anticipated that the proposed development will not induce significant traffic impact to the surrounding road network.
- 6.1.5 At present, the Application Site is served by a local access road located along the eastern side of the Application Site, which also serves other village developments in the area. Under the proposed development scheme, the local access road will be upgraded to a standard 7.3m single carriageway with footpaths on both sides. Two vehicular accesses are provided at the local access road to serve the development. One access will be located to the southern side of the Application Site to serve the residential blocks while another access will be located at the mid-way along the access road to serve mainly the commercial building and as the secondary access for the residential blocks.
- 6.1.6 Taking into consideration the future planning at Ping Che area and the relatively large area of the Application Site, a public transport terminus (PTT) is proposed at the northern part of the Application Site along Ping Che Road. The PTT will comprise of a double width bus bay and a GMB bay. The ingress point is located at the upgraded access road and the egress point is located at Ping Che Road to provide better circulations within the PTT.
- 6.1.7 The proposed development will provide 725 nos. of private car parking spaces (including 6 nos. of parking space for disabled users), 18 goods vehicle loading / unloading bays, 33 motorcycle parking spaces, 2 lay-bys for taxi and private car and 1 lay-by for single-deck tour bus to fulfil the HKPSG requirements.

6.2 Conclusion

- 6.2.1 Based on the assessment result, it can be concluded that the proposed development will not induce significant traffic impact on the surrounding road network. The development proposal is considered acceptable from traffic engineering point of view.

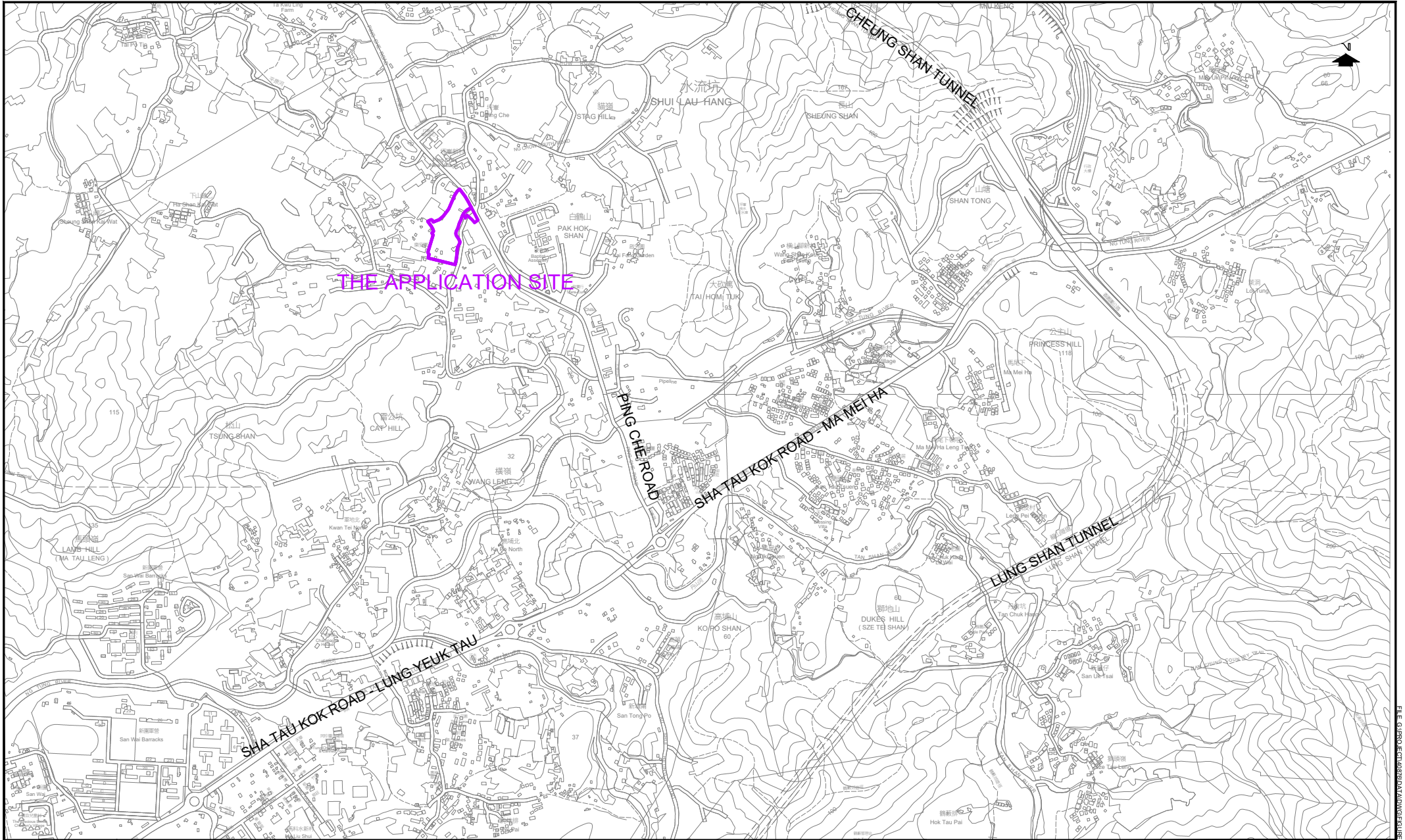

PROJECT NO.	40876	
DESIGNED	SLN	DATE SEP 2023
DRAWN	CLL	SCALE 1:15000 @ A4
CHECKED	SLN	

PROJECT TITLE APPLICATION FOR AMENDMENT OF PLAN UNDER SECTION 12A OF THE TOWN PLANNING ORDINANCE (CAP. 131) FOR MIXED USE DEVELOPMENT (RESIDENTIAL AND COMMERCIAL) AT LOT 796 AND 1008 RP IN D.D. 77 AND ADJOINING GOVERNMENT LAND IN PING CHE, TA KWU LING, NEW TERRITORIES

DRAWING TITLE	LOCATION PLAN	
---------------	----------------------	--

DRAWING NO.	FIGURE 1.1	REV.	.
-------------	------------	------	---



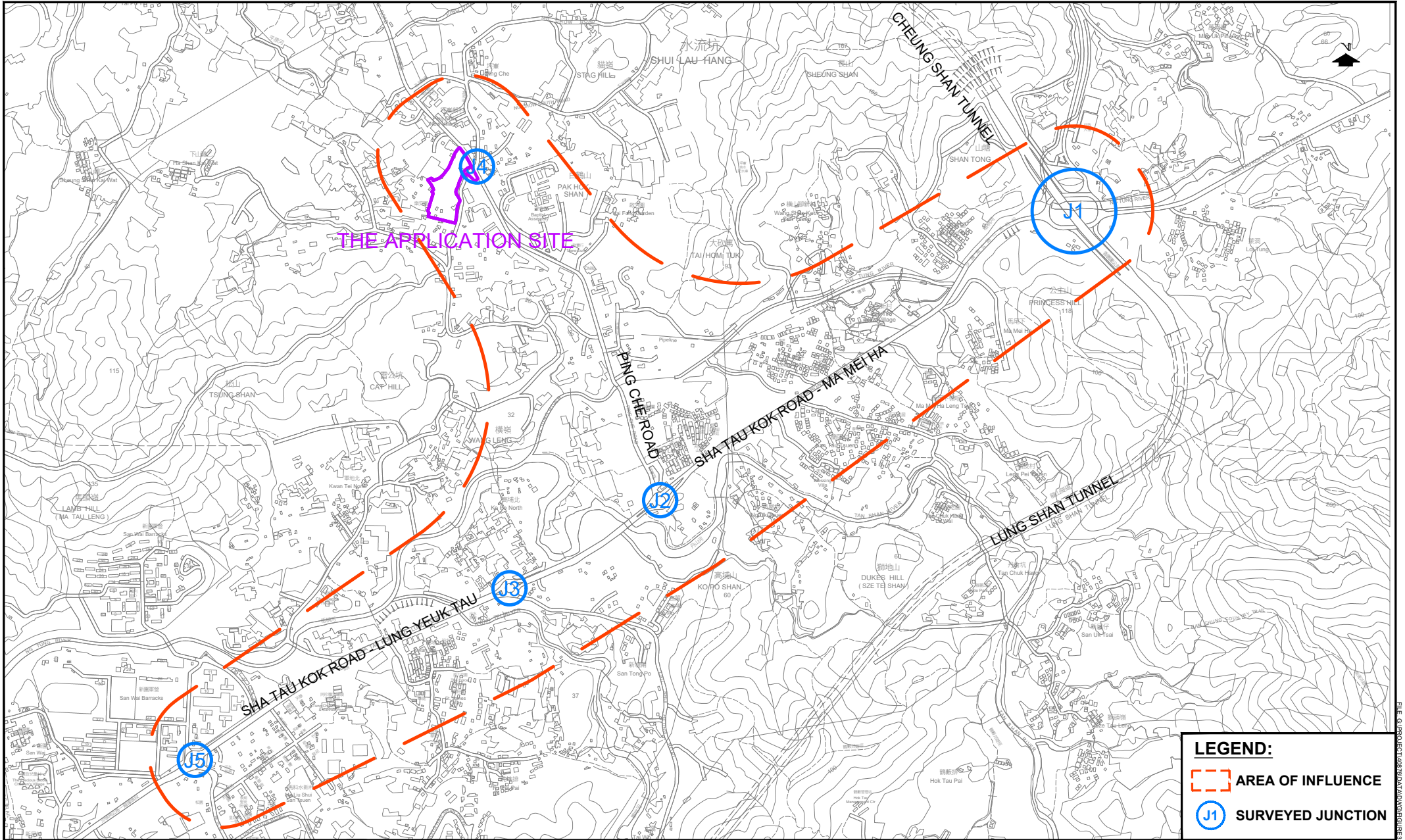

LEGEND:

- AREA OF INFLUENCE
- J1 SURVEYED JUNCTION

PROJECT NO.		40876	
DESIGNED	SLN	DATE	SEP 2023
DRAWN	CLL	SCALE	1:15000 @ A4
CHECKED	SLN		

PROJECT TITLE APPLICATION FOR AMENDMENT OF PLAN UNDER SECTION 12A OF THE TOWN PLANNING ORDINANCE (CAP. 131) FOR MIXED USE DEVELOPMENT (RESIDENTIAL AND COMMERCIAL) AT LOT 796 AND 1008 RP IN D.D. 77 AND ADJOINING GOVERNMENT LAND IN PING CHE, TA KWU LING, NEW TERRITORIES

DRAWING NO.	REV.
FIGURE 3.1	A

LOCATION OF SURVEYED JUNCTIONS AND AREA OF INFLUENCE

LLA 顧問有限公司
Consultancy Limited

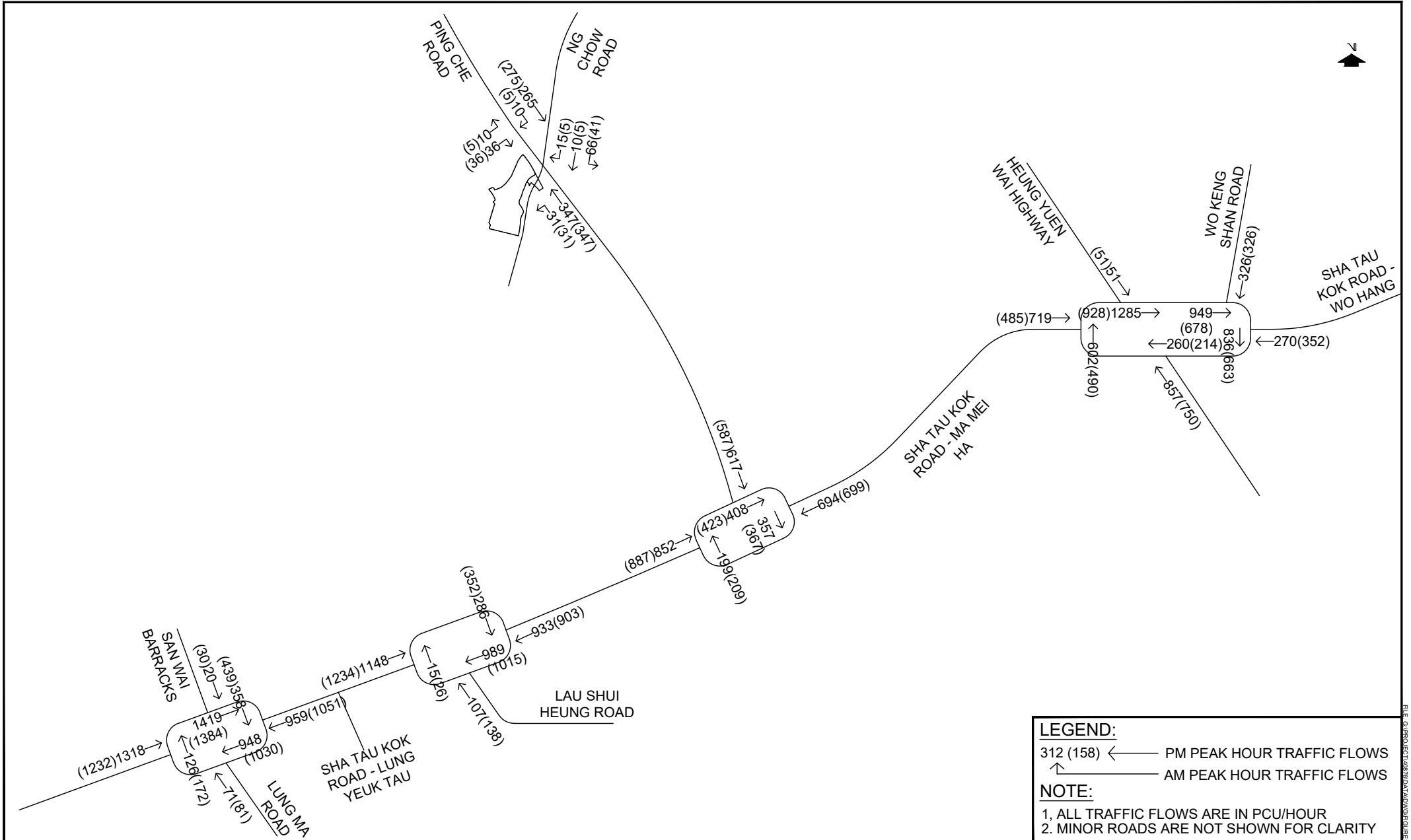

LEGEND:
 312 (158) PM PEAK HOUR TRAFFIC FLOWS
 AM PEAK HOUR TRAFFIC FLOWS

NOTE:
 1, ALL TRAFFIC FLOWS ARE IN PCU/HOUR
 2, MINOR ROADS ARE NOT SHOWN FOR CLARITY

PROJECT NO.	40876	
DESIGNED	SLN	DATE FEB 2024
DRAWN	CLL	SCALE
CHECKED	SLN	N.T.S.

PROJECT TITLE	APPLICATION FOR AMENDMENT OF PLAN UNDER SECTION 12A OF THE TOWN PLANNING ORDINANCE (CAP. 131) FOR MIXED USE DEVELOPMENT (RESIDENTIAL AND COMMERCIAL) AT LOT 796 AND 1008 RP IN D.D. 77 AND ADJOINING GOVERNMENT LAND IN PING CHE, TA KWU LING, NEW TERRITORIES
DRAWING TITLE	2023 EXISTING TRAFFIC FLOWS

DRAWING NO.	FIGURE 3.2	REV.	A
LLA 顧問有限公司 Consultancy Limited			

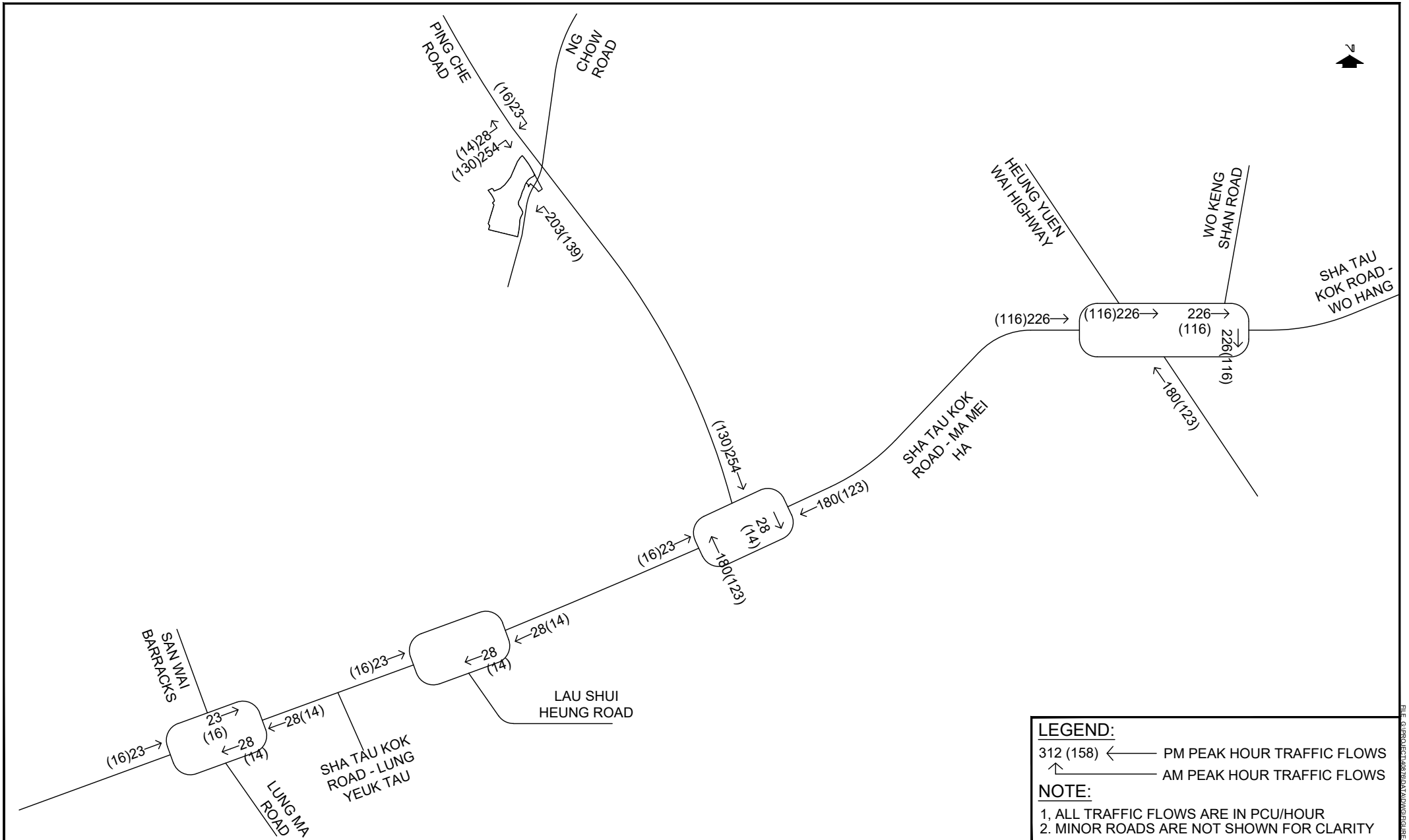

PROJECT NO.		40876	
DESIGNED	SLN	DATE	FEB 2024
DRAWN	CLL	SCALE	N.T.S.
CHECKED	SLN		

PROJECT TITLE		APPLICATION FOR AMENDMENT OF PLAN UNDER SECTION 12A OF THE TOWN PLANNING ORDINANCE (CAP. 131) FOR MIXED USE DEVELOPMENT (RESIDENTIAL AND COMMERCIAL) AT LOT 796 AND 1008 RP IN D.D. 77 AND ADJOINING GOVERNMENT LAND IN PING CHE, TA KWU LING, NEW TERRITORIES	
DRAWING TITLE		DEVELOPMENT TRAFFIC FLOWS	

DRAWING NO.	FIGURE 4.1	REV.	A
LLA 顧問有限公司 Consultancy Limited			

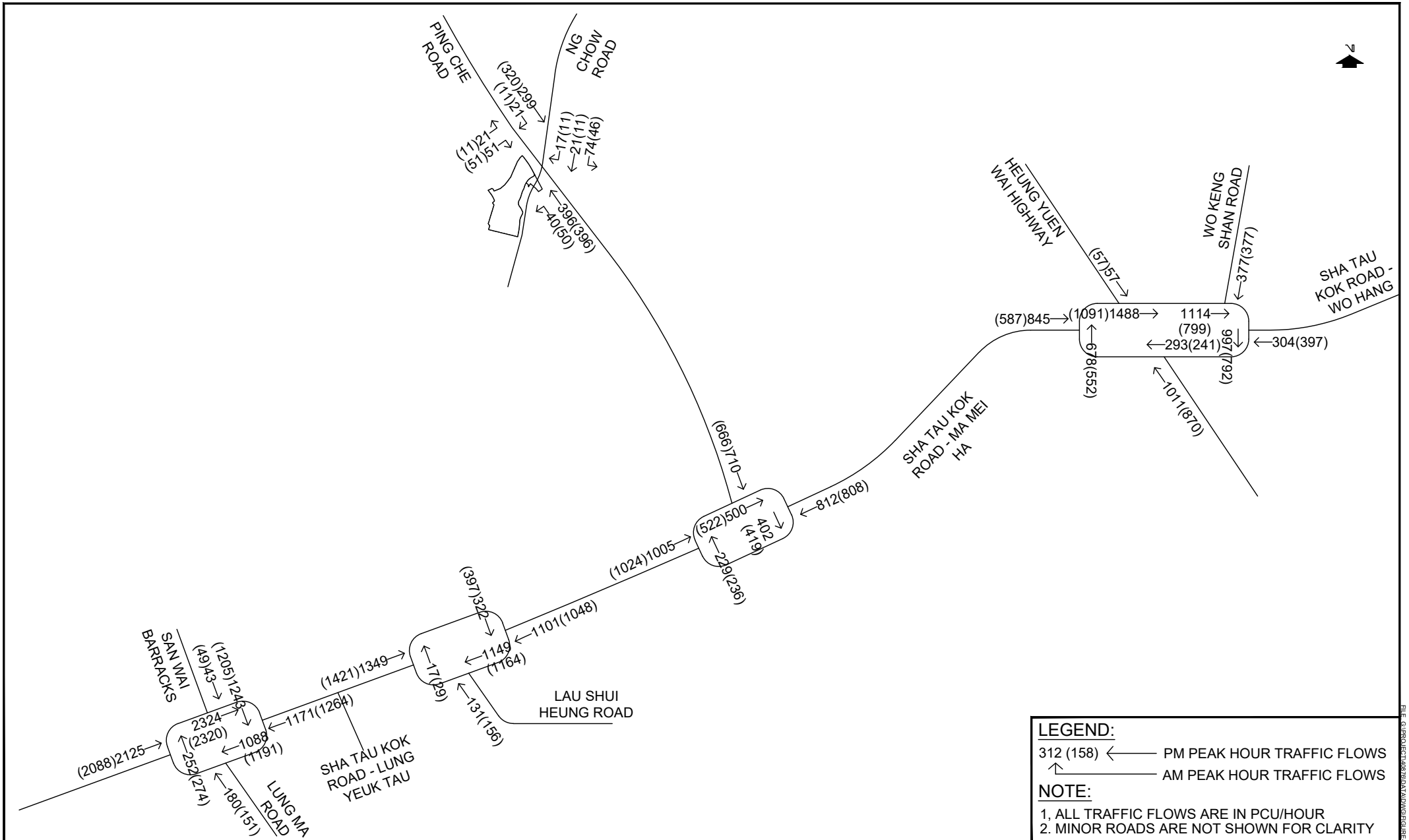

PROJECT NO. 40876	
DESIGNED SLN	DATE FEB 2024
DRAWN CLL	SCALE N.T.S.
CHECKED SLN	

PROJECT TITLE APPLICATION FOR AMENDMENT OF PLAN UNDER SECTION 12A OF THE TOWN PLANNING ORDINANCE (CAP. 131) FOR MIXED USE DEVELOPMENT (RESIDENTIAL AND COMMERCIAL) AT LOT 796 AND 1008 RP IN D.D. 77 AND ADJOINING GOVERNMENT LAND IN PING CHE, TA KWU LING, NEW TERRITORIES	
DRAWING TITLE 2035 REFERENCE TRAFFIC FLOWS	

DRAWING NO. FIGURE 4.2	REV. A
LLA 顧問有限公司 Consultancy Limited	

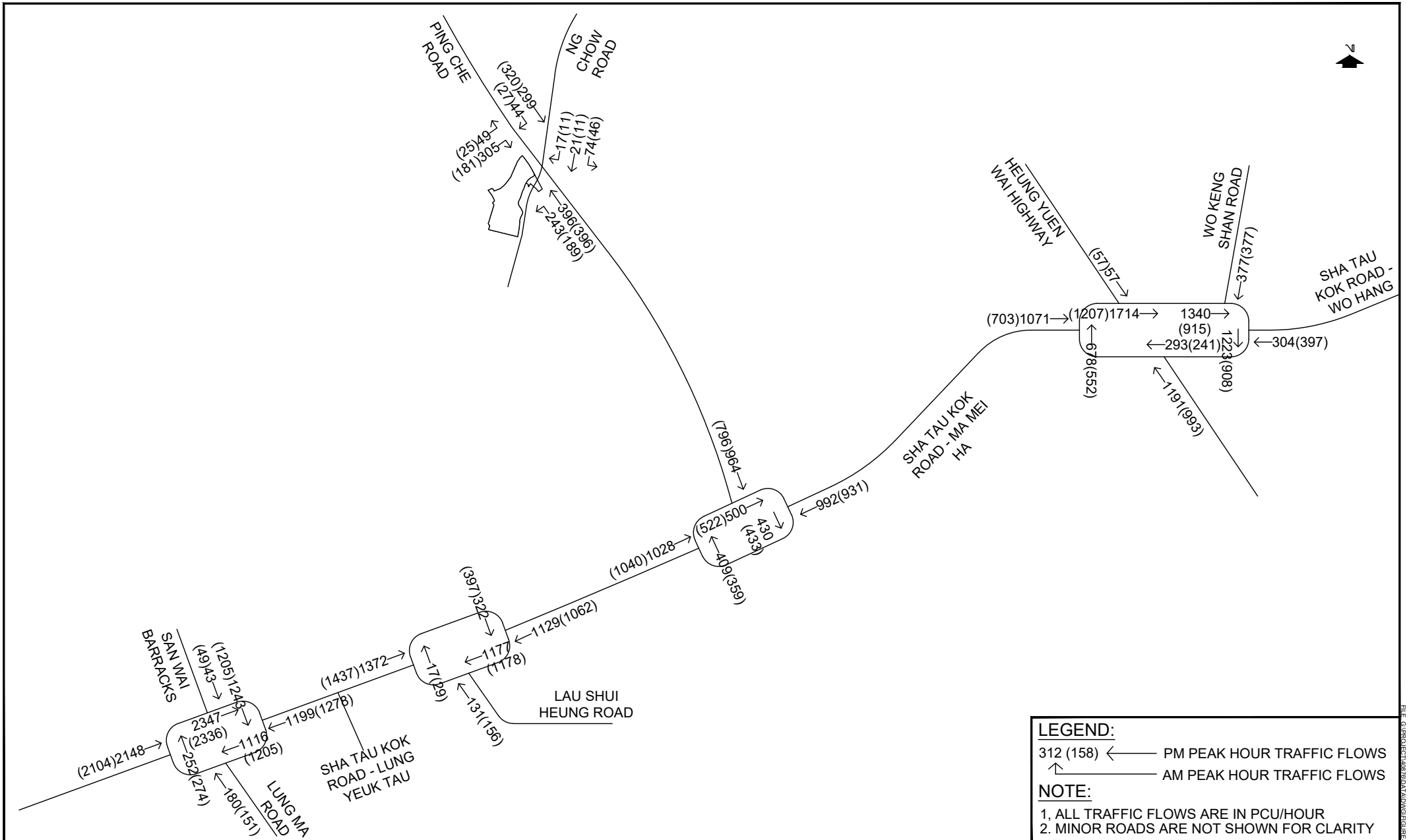

LEGEND:
 312 (158) ←—— PM PEAK HOUR TRAFFIC FLOWS
 ——— AM PEAK HOUR TRAFFIC FLOWS

NOTE:
 1, ALL TRAFFIC FLOWS ARE IN PCU/HOUR
 2, MINOR ROADS ARE NOT SHOWN FOR CLARITY

PROJECT NO. 40876	
DESIGNED SLN	DATE FEB 2024
DRAWN CLL	SCALE N.T.S.
CHECKED SLN	

PROJECT TITLE
 APPLICATION FOR AMENDMENT OF PLAN UNDER SECTION 12A OF THE TOWN PLANNING ORDINANCE (CAP. 131) FOR MIXED USE DEVELOPMENT (RESIDENTIAL AND COMMERCIAL) AT LOT 796 AND 1008 RP IN D.D. 77 AND ADJOINING GOVERNMENT LAND IN PING CHE, TA KWU LING, NEW TERRITORIES

DRAWING TITLE
2035 DESIGN TRAFFIC FLOWS

DRAWING NO. FIGURE 4.3	REV. A
LLA 顧問有限公司 Consultancy Limited	

Appendix A
Junction Capacity Assessments
- Existing Scenario

LLA CONSULTANCY LIMITED

Job Title: Application for Amendment of Plan under Section 12A for the Town Planning Ordinance (Cap. 131) for Mixed Use Development at Lot 796 and 1008RP in D.D. 77 and Adjoining Government Land in Ping Che, Ta Kwo Ling, New Territories

J1 Sha Tau Kok Road / Heung Yuen Wai Highway

ROUNDABOUT CALCULATION

PROJECT NO.: 40876
 FILENAME J1_STKR_HYWH.xls
 REFERENCE NO.:
 PREPARED BY: SKL
 CHECKED BY: SLN
 REVIEWED BY: SLN
 DATE: Oct-23

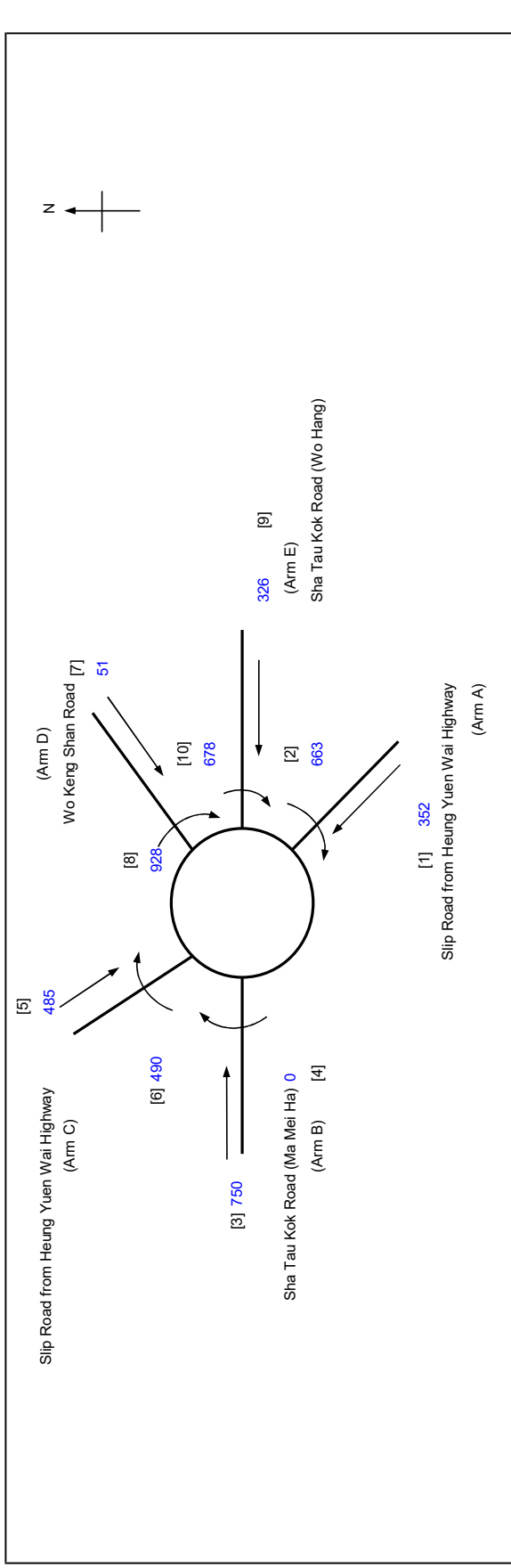

ARM	A	B	C	D	E
V	4.00	3.30	4.00	3.90	3.70
E	9.90	7.60	9.80	7.70	7.70
L	24.00	33.00	28.00	27.00	35.00
R	60.00	40.00	40.00	44.00	27.00
D	50.00	50.00	50.00	50.00	50.00
A	35.00	35.00	35.00	35.00	10.00
Q	352	750	485	51	326
Qc	663	0	490	928	678

INPUT PARAMETERS:	A	B	C	D	E
V	4.00	3.30	4.00	3.90	3.70
E	9.90	7.60	9.80	7.70	7.70
L	24.00	33.00	28.00	27.00	35.00
R	60.00	40.00	40.00	44.00	27.00
D	50.00	50.00	50.00	50.00	50.00
A	35.00	35.00	35.00	35.00	10.00
Q	352	750	485	51	326
Qc	663	0	490	928	678

OUTPUT PARAMETERS:	A	B	C	D	E
S	0.39	0.21	0.33	0.23	0.18
K	1.02	1.01	1.01	1.01	1.08
X2	7.30	6.33	7.49	6.52	6.63
M	0	0	0	0	0
F	2213	1919	2269	1976	2009
Td	1.37	1.37	1.37	1.37	1.37
Fc	0.71	0.65	0.72	0.66	0.67
Qe	1771	1933	1932	1375	1684

DFC	=	Design flow/Capacity = Q/Qe	0.20	0.39	0.25	0.04	0.19
Total In Sum =							1964
DFC of Critical Approach =							0.39

LLA CONSULTANCY LIMITED

Job Title: Application for Amendment of Plan under Section 12A for the Town Planning Ordinance (Cap. 131) for Mixed Use Development at Lot 796 and 1008RP in D.D. 77 and Adjoining Government Land in Ping Che, Ta Kwu Ling, New Territories

J2 Sha Tau Kok Road / Ping Che Road

ROUNDABOUT CALCULATION

2023 Existing AM

PROJECT NO.: 40876

FILENAME: J2_STKR_PCR.xlsx

REFERENCE NO.:

INITIALS

PREPARED BY:

CHECKED BY:

REVIEWED BY:

DATE

SKL

SLN

SLN

SKL

SLN

SLN

PREPARED BY:

CHECKED BY:

REVIEWED BY:

SKL

SLN

SLN

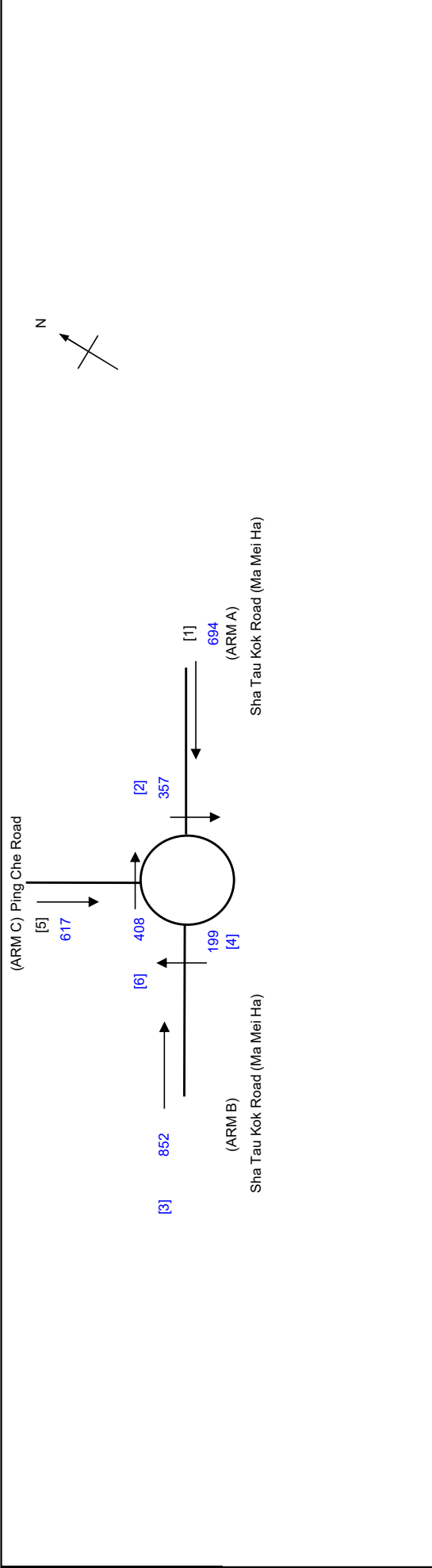

ARM

	A	B	C
V = Approach half width (m)	7.40	7.30	4.10
E = Entry width (m)	8.20	7.90	8.10
L = Effective length of flare (m)	1.00	1.00	5.00
R = Entry radius (m)	75.00	60.00	40.00
D = Inscribed circle diameter (m)	53.00	53.00	53.00
A = Entry angle (degree)	10.00	15.00	10.00
Q = Entry flow (pcu/h)	694	852	617
Qc = Circulating flow across entry (pcu/h)	357	199	408

OUTPUT PARAMETERS:

S = Sharpness of flare = $1.6(E-V)/L$	1.28	0.96	1.28
K = $1-0.00347(A-30)+0.978(1/R-0.05)$	1.11	1.08	1.09
X2 = $V + ((E-V)/(1+2S))$	7.62	7.51	5.22
M = $EXP((D-60)/10)$	0.50	0.50	0.50
F = $303 \times X2$	2310	2274	1583
Td = $1+(0.5/(1+M))$	1.33	1.33	1.33
Fc = $0.21 \times Td(1+0.2 \times X2)$	0.71	0.70	0.57
Qe = $K(F-Fc)Qc$	2274	2315	1476

DFC = Design flow/Capacity = Q/Qe

0.31 0.37 0.42

Total In Sum =

3127 PCU

DFC of Critical Approach =

0.42

LLA CONSULTANCY LIMITED

Job Title: Application for Amendment of Plan under Section 12A for the Town Planning Ordinance (Cap. 131) for Mixed Use Development at Lot 796 and 1008RP in D.D. 77 and Adjoining Government Land in Ping Che, Ta Kwu Ling, New Territories

J2 Sha Tau Kok Road / Ping Che Road

ROUNDABOUT CALCULATION

PROJECT NO.: 40876
FILENAME: J2_STKR_PCR.xlsx
REFERENCE NO.:

PREPARED BY:
CHECKED BY:
REVIEWED BY:

INITIALS
SKL
SLN
SLN

DATE
Oct-23
Oct-23
Oct-23

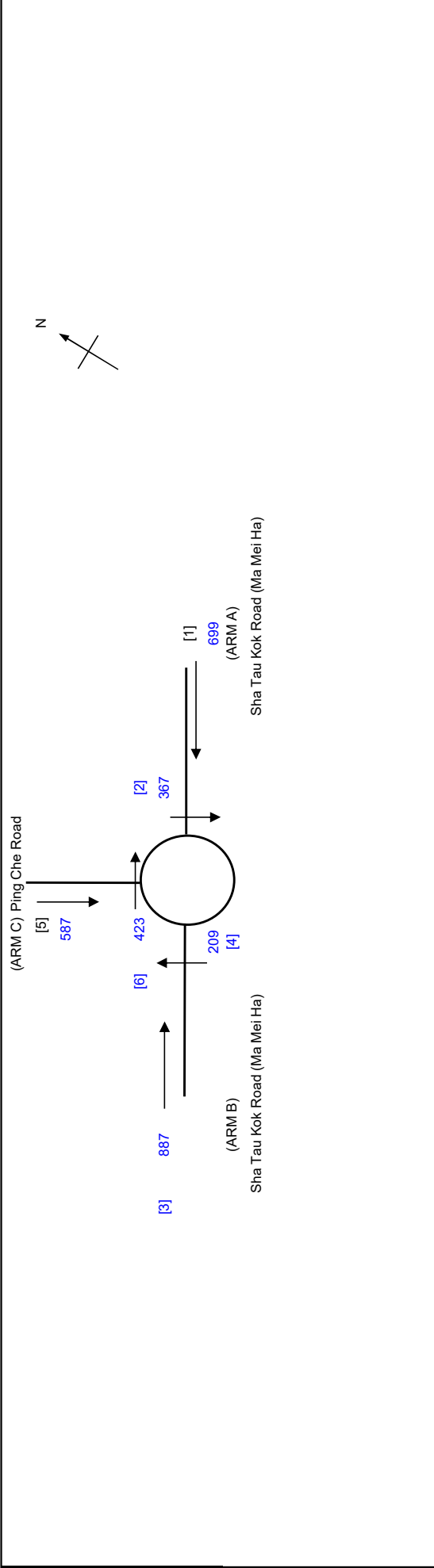

ARM

	A	B	C
V = Approach half width (m)	7.40	7.30	4.10
E = Entry width (m)	8.20	7.90	8.10
L = Effective length of flare (m)	1.00	1.00	5.00
R = Entry radius (m)	75.00	60.00	40.00
D = Inscribed circle diameter (m)	53.00	53.00	53.00
A = Entry angle (degree)	10.00	15.00	10.00
Q = Entry flow (pcu/h)	699	887	587
Qc = Circulating flow across entry (pcu/h)	367	209	423

OUTPUT PARAMETERS:

S = Sharpness of flare = 1.6(E-V)/L	1.28	0.96	1.28
K = 1-0.00347(A-30)+0.978(1/R-0.05)	1.11	1.08	1.09
X2 = V + ((E-V)/(1+2S))	7.62	7.51	5.22
M = EXP((D-60)/10)	0.50	0.50	0.50
F = 303*X2	2310	2274	1583
Td = 1+(0.5/(1+M))	1.33	1.33	1.33
Fc = 0.21*Td(1+0.2*X2)	0.71	0.70	0.57
Qe = K(F-Fc*Qc)	2267	2308	1466

DFC = Design flow/Capacity = Q/Qe

Total In Sum = 3172 PCU

DFC of Critical Approach = 0.40

LLA CONSULTANCY LIMITED

Job Application for Amendment of Plan under Section 12A for the Town Planning Ordinance (Cap. 131) for Mixed Use Development at Lot 796 and 1008RP in D.D. 77 and Adjoining Government Land in Ping Che, Ta Kwu Ling, New Territories

J3 Sha Tau Kok Road / Lau Shui Heung Road

ROUNDABOUT CALCULATION

PROJECT NO.: 40876
 FILENAME: J3_STKR_LSHR.x
 REFERENCE NO.:
 PREPARED BY: SKL
 CHECKED BY: SLN
 REVIEWED BY: SLN
 DATE: Oct-23

2023 Existing AM

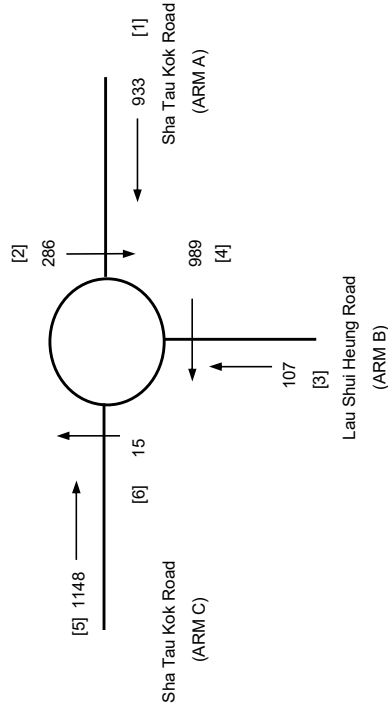

ARM

INPUT PARAMETERS:

	A	B	C
V = Approach half width (m)	6.30	3.60	6.60
E = Entry width (m)	6.90	5.60	7.00
L = Effective length of flare (m)	1.00	7.00	1.00
R = Entry radius (m)	80.00	110.00	16.00
D = Inscribed circle diameter (m)	53.00	53.00	53.00
A = Entry angle (degree)	15.00	15.00	15.00
Q = Entry flow (pcu/h)	933	107	1148
Qc = Circulating flow across entry (pcu/h)	286	989	15

OUTPUT PARAMETERS:

S = Sharpness of flare = 1.6(E-V)/L	0.96	0.46	0.64
K = 1-0.00347(A-30)-0.978(1/R-0.05)	1.09	1.09	1.04
X2 = V + ((E-V)/(1+2S))	6.51	4.64	6.78
M = EXP((D-60)/10)	0.50	0.50	0.50
F = 303*X2	1971	1407	2053
Td = 1+(0.5/(1+M))	1.33	1.33	1.33
Fc = 0.21*Td(1+0.2*X2)	0.64	0.54	0.66
Qe = K(F-Fc*Qc)	1945	953	2124

DFC = Design flow/Capacity = Q/Qe

Total In Sum = 2188 PCU

DFC of Critical Approach = 0.54

LLA CONSULTANCY LIMITED

Job Application for Amendment of Plan under Section 12A for the Town Planning Ordinance (Cap. 131) for Mixed Use Development at Lot 796 and 1008RP in D.D. 77 and Adjoining Government Land in Ping Che, Ta Kwu Ling, New Territories

J3 Sha Tau Kok Road / Lau Shui Heung Road

ROUNDABOUT CALCULATION

PROJECT NO.:	40876	PREPARED BY:	SKL	INITIALS	DATE
FILENAME :	J3_STKR_LSHR.x	CHECKED BY:	SLN		Oct-23
REFERENCE NO.:		REVIEWED BY:	SLN		Oct-23

2023 Existing PM

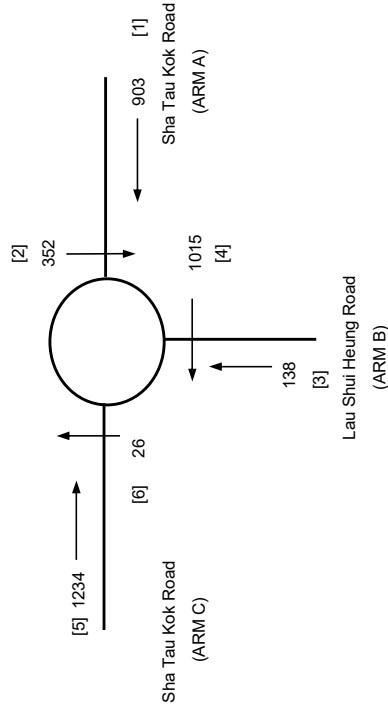

ARM

INPUT PARAMETERS:

	A	B	C
V = Approach half width (m)	6.30	3.60	6.60
E = Entry width (m)	6.90	5.60	7.00
L = Effective length of flare (m)	1.00	7.00	1.00
R = Entry radius (m)	80.00	110.00	16.00
D = Inscribed circle diameter (m)	53.00	53.00	53.00
A = Entry angle (degree)	15.00	15.00	15.00
Q = Entry flow (pcu/h)	903	138	1234
Qc = Circulating flow across entry (pcu/h)	352	1015	26

OUTPUT PARAMETERS:

S = Sharpness of flare = 1.6(E-V)/L	0.96	0.46	0.64
K = 1-0.00347(A-30)-0.978(1/R-0.05)	1.09	1.09	1.04
X2 = V + ((E-V)/(1+2S))	6.51	4.64	6.78
M = EXP((D-60)/10)	0.50	0.50	0.50
F = 303*X2	1971	1407	2053
Td = 1+(0.5/(1+M))	1.33	1.33	1.33
Fc = 0.21*Td(1+0.2*X2)	0.64	0.54	0.66
Qe = K(F-Fc*Qc)	1899	938	2117

DFC = Design flow/Capacity = Q/Qe

Total In Sum = 2275 PCU

DFC of Critical Approach = 0.58

LLA CONSULTANCY LIMITED

Application for Amendment of Plan under Section 12A for the Town Planning Ordinance (Cap. 131) for Mixed Use Development at Lot 796 and 1008RP in D.D. 77 and Adjoining Government Land in Ping Che, Ta Kwu Ling, New Territories

PRIORITY JUNCTION CALCULATION

2023 Existing AM

PROJECT NO.: 40876
 FILENAME: J4_PCR_NCR.xlsx
 REFERENCE NO.:

INITIALS
 SKL
 SLN
 SLN

DATE
 Oct-23
 Oct-23
 Oct-23

J4 Ping Che Road / Ng Chow Road

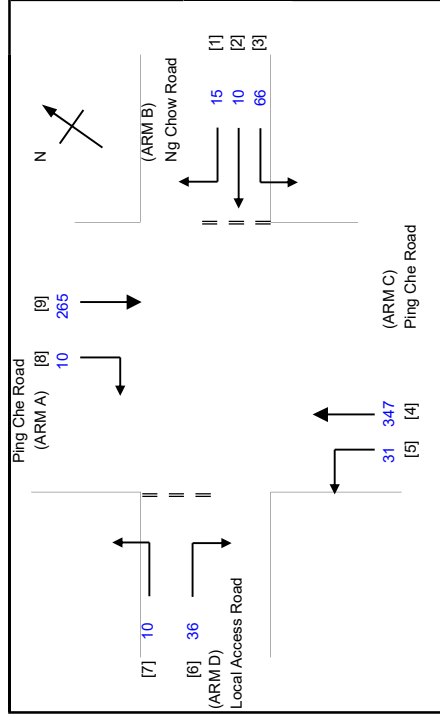

NOTES : (GEOMETRIC INPUT DATA)

- W = MAJOR ROAD WIDTH
- W cr = CENTRAL RESERVE WIDTH
- W b-a = LANE WIDTH AVAILABLE TO VEHICLE WAITING IN STREAM b-a
- W b-c = LANE WIDTH AVAILABLE TO VEHICLE WAITING IN STREAM b-c
- W c-b = LANE WIDTH AVAILABLE TO VEHICLE WAITING IN STREAM c-b
- Vi b-a = VISIBILITY TO THE LEFT FOR VEHICLES WAITING IN STREAM b-a
- Vi b-c = VISIBILITY TO THE RIGHT FOR VEHICLES WAITING IN STREAM b-a
- Vi c-b = VISIBILITY TO THE RIGHT FOR VEHICLES WAITING IN STREAM b-c
- X a = STREAM-SPECIFIC (RIGHT TURN FROM A)
- X b = STREAM-SPECIFIC (RIGHT TURN FROM B)
- Z b = STREAM-SPECIFIC (LEFT TURN FROM B)
- M b = STREAM-SPECIFIC (STRAIGHT AHEAD FROM B - LEFT LANE)
- Y = (1-0.0345W)
- r b-a = RATIO OF FLOW TO CAPACITY IN STREAM b-a

GEOMETRIC DETAILS:

GENERAL					
W	=	7.30	(metres)		
W cr	=	0	(metres)	Y	= 0.748
MAJOR ROAD (ARM A)					
W a-d	=	3.65	(metres)	W c-b	= 0.00 (metres)
Vi a-d	=	100	(metres)	Vi c-b	= 0 (metres)
q a-b	=	0	(pcu/hr)	q c-a	= 347 (pcu/hr)
q a-c	=	265	(pcu/hr)	q c-b	= 0 (pcu/hr)
q a-d	=	10	(pcu/hr)	q c-d	= 31 (pcu/hr)
MINOR ROAD (ARM B)					
W b-a	=	0.00	(metres)	W d-c	= 3.40 (metres)
W b-c	=	5.00	(metres)	W d-a	= 0.00 (metres)
Vi b-a	=	30	(metres)	Vi d-c	= 18 (metres)
Vi b-c	=	18	(metres)	Vi d-a	= 19 (metres)
q b-a	=	15	(pcu/hr)	q d-c	= 36 (pcu/hr)
q b-c	=	66	(pcu/hr)	q d-a	= 10 (pcu/hr)
q b-d	=	10	(pcu/hr)	q d-b	= 0 (pcu/hr)

GEOMETRIC FACTORS :

X b	=	0.554	X a	=	0.982
X c	=	0.586	X d	=	0.817
Z b	=	1.023	Z d	=	0.597
M b	=	0.950	M d	=	0.550
PROPORTION OF MINOR STRAIGHT AHEAD TRAFFIC :					
r b-a	=	0.0401	r d-c	=	0.096
qi b-d	=	5.2005 (pcu/hr)	qi d-b	=	0 (pcu/hr)
qr b-d	=	4.7995 (pcu/hr)	qr d-b	=	0 (pcu/hr)
CAPACITY OF MOVEMENT :					
Q b-a	=	269 (pcu/hr)	Q d-c	=	374 (pcu/hr)
Q b-c	=	682 (pcu/hr)	Q d-a	=	377 (pcu/hr)
Q c-b	=	392 (pcu/hr)	Q d-b	=	631 (pcu/hr)
Qi b-d	=	463 (pcu/hr)	Qi d-b	=	264 (pcu/hr)
Qr b-d	=	270 (pcu/hr)	Qr d-b	=	392 (pcu/hr)
Q b-abc	=	480 (pcu/hr)	Q d-abc	=	375 (pcu/hr)
				TOTAL FLOW =	790 (PCU/HR)

COMPARISON OF DESIGN FLOW TO CAPACITY:

DFC b-a	=	0.0558
DFC b-c	=	0.0968
DFC c-b	=	0.0000
DFCI b-d	=	0.0112
DFCr b-d	=	0.0178
DFC d-c	=	0.0963
DFC d-a	=	0.0265
DFC a-d	=	0.0158
DFCI d-b	=	0.0000
DFCr d-b	=	0.0000
DFC b-acd (shared lane)	=	0.1897
DFC d-abc (shared lane)	=	0.1228

CRITICAL DFC = 0.19

LLA CONSULTANCY LIMITED

Application for Amendment of Plan under Section 12A for the Town Planning Ordinance (Cap. 131) for Mixed Use Development at Lot 796 and 1008RP in D.D. 77 and Adjoining Government Land in Ping Che, Ta Kwu Ling, New Territories

PRIORITY JUNCTION CALCULATION

2023 Existing PM

INITIALS

DATE

SKL

SLN

PREPARED BY:

40876

J4_PCR_NCR.xlsx

FILENAME:

40876

SLN

PREPARED BY:

40876

CHECKED BY:

40876

SLN

REVIEWED BY:

40876

SLN

REFERENCE NO.:

40876

J4 Ping Che Road / Ng Chow Road

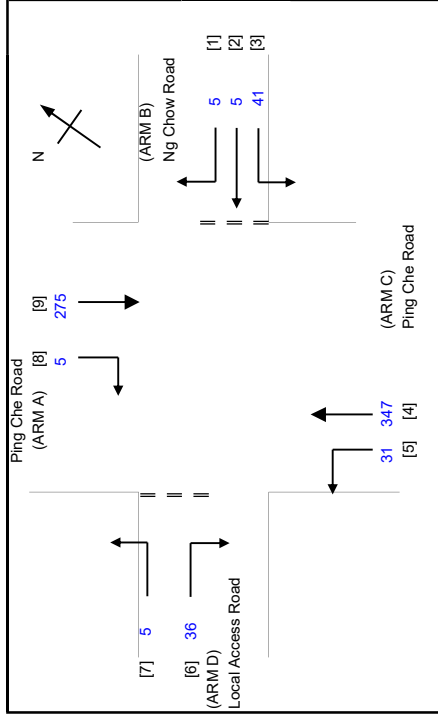

NOTES : (GEOMETRIC INPUT DATA)

- W = MAJOR ROAD WIDTH
- W cr = CENTRAL RESERVE WIDTH
- W b-a = LANE WIDTH AVAILABLE TO VEHICLE WAITING IN STREAM b-a
- W b-c = LANE WIDTH AVAILABLE TO VEHICLE WAITING IN STREAM b-c
- W c-b = LANE WIDTH AVAILABLE TO VEHICLE WAITING IN STREAM c-b
- V b-a = VISIBILITY TO THE LEFT FOR VEHICLES WAITING IN STREAM b-a
- V r b-a = VISIBILITY TO THE RIGHT FOR VEHICLES WAITING IN STREAM b-a
- V r b-c = VISIBILITY TO THE RIGHT FOR VEHICLES WAITING IN STREAM b-c
- V r c-b = VISIBILITY TO THE RIGHT FOR VEHICLES WAITING IN STREAM c-b
- X a = STREAM-SPECIFIC (RIGHT TURN FROM A)
- X b = STREAM-SPECIFIC (RIGHT TURN FROM B)
- Z b = STREAM-SPECIFIC (LEFT TURN FROM B)
- M b = STREAM-SPECIFIC (STRAIGHT AHEAD FROM B - LEFT LANE)
- Y = (1-0.0345W)
- r b-a = RATIO OF FLOW TO CAPACITY IN STREAM b-a

GEOMETRIC DETAILS:

GENERAL					
W	=	7.30	(metres)		
W cr	=	0	(metres)	Y	= 0.748
MAJOR ROAD (ARM A)					
W a-d	=	3.65	(metres)	W c-b	= 0.00 (metres)
V r a-d	=	100	(metres)	V r c-b	= 0 (metres)
q a-b	=	0	(pcu/hr)	q c-a	= 347 (pcu/hr)
q a-c	=	275	(pcu/hr)	q c-b	= 0 (pcu/hr)
q a-d	=	5	(pcu/hr)	q c-d	= 31 (pcu/hr)
MINOR ROAD (ARM B)					
W b-a	=	0.00	(metres)	W d-c	= 3.40 (metres)
W b-c	=	5.00	(metres)	W d-a	= 0.00 (metres)
V l b-a	=	30	(metres)	V l d-c	= 18 (metres)
V r b-a	=	18	(metres)	V r d-c	= 19 (metres)
V r b-c	=	18	(metres)	V r d-a	= 19 (metres)
q b-a	=	5	(pcu/hr)	q d-c	= 36 (pcu/hr)
q b-c	=	41	(pcu/hr)	q d-a	= 5 (pcu/hr)
q b-d	=	5	(pcu/hr)	q d-b	= 0 (pcu/hr)

GEOMETRIC FACTORS :

X b	=	0.554	X a	=	0.982
X c	=	0.586	X d	=	0.817
Z b	=	1.023	Z d	=	0.597
M b	=	0.950	M d	=	0.550
PROPORTION OF MINOR STRAIGHT AHEAD TRAFFIC :					
r b-a	=	0.0131	r d-c	=	0.094
q l b-d	=	2.5327	q l d-b	=	0 (pcu/hr)
q r b-d	=	2.4673	q r d-b	=	0 (pcu/hr)
CAPACITY OF MOVEMENT :					
Q b-a	=	269	(pcu/hr)	Q d-c	= 382 (pcu/hr)
Q b-c	=	684	(pcu/hr)	Q d-a	= 377 (pcu/hr)
Q c-b	=	392	(pcu/hr)	Q d-d	= 631 (pcu/hr)
Q l b-d	=	462	(pcu/hr)	Q l d-b	= 264 (pcu/hr)
Q r b-d	=	269	(pcu/hr)	Q r d-b	= 392 (pcu/hr)
Q b-acc	=	525	(pcu/hr)	Q d-abc	= 381 (pcu/hr)
				TOTAL FLOW =	750 (PCU/HR)

COMPARISON OF DESIGN FLOW TO CAPACITY:

DFC b-a	=	0.0186
DFC b-c	=	0.0599
DFC c-b	=	0.0000
DFCI b-d	=	0.0055
DFCr b-d	=	0.0092
DFC d-c	=	0.0942
DFC d-a	=	0.0133
DFC a-d	=	0.0079
DFCI d-b	=	0.0000
DFCr d-b	=	0.0000
DFC b-acc (shared lane)	=	0.0971
DFC d-abc (shared lane)	=	0.1075

CRITICAL DFC = 0.11

LLA CONSULTANCY LIMITED

Application for Amendment of Plan under Section 12A for the Town Planning Ordinance (Cap. 131) for Mixed Use Development at Lot 796 and 1008RP in D.D. 77 and Adjoining Government Land in Ping Che, Ta Kwu Ling, New Territories

J5 Sha Tau Kok Road / Lung Ma Road

ROUNDABOUT CALCULATION

PROJECT NO.: 40876
 FILENAME: J5_STKR_LMR.xls
 REFERENCE NO.:
 PREPARED BY: SKL
 CHECKED BY: SLN
 REVIEWED BY: SLN
 DATE: Feb-24

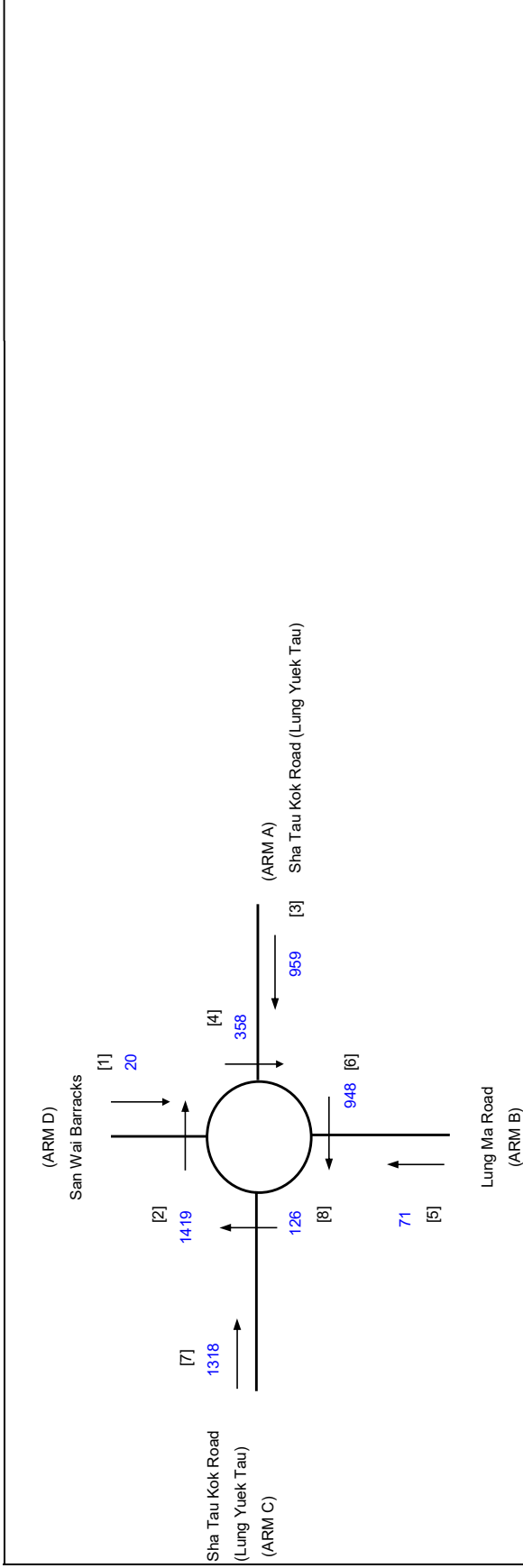

ARM	A	B	C	D
V = Approach half width (m)	7.30	3.50	7.30	3.00
E = Entry width (m)	10.00	7.00	9.50	5.00
L = Effective length of flare (m)	11.00	20.00	30.00	15.00
R = Entry radius (m)	20.00	100.00	30.00	35.00
D = Inscribed circle diameter (m)	55.00	55.00	55.00	55.00
A = Entry angle (degree)	20.00	10.00	9.00	15.00
Q = Entry flow (pcu/h)	959	71	1318	20
Qc = Circulating flow across entry (pcu/h)	358	948	126	1419
OUTPUT PARAMETERS:				
S = Sharpness of flare = $1.6(E-V)/L$	0.39	0.28	0.12	0.21
K = $1-0.00347(A-30)-0.978(1/R-0.05)$	1.03	1.11	1.09	1.07
X2 = $V + ((E-V)/(1+2S))$	8.81	5.74	9.08	4.40
M = $EXP((D-60)/10)$	0.61	0.61	0.61	0.61
F = $303*X2$	2670	1740	2752	1334
Td = $1+(0.5/(1+M))$	1.31	1.31	1.31	1.31
Fc = $0.21*Td(1+0.2*X2)$	0.76	0.59	0.78	0.52
Qe = $K(F-Fc*Qc)$	2481	1307	2891	643
Total In Sum = 2368 PCU				
DFC = Design flow/Capacity = Q/Qe	0.39	0.05	0.46	0.03
DFC of Critical Approach = 0.46				

LLA CONSULTANCY LIMITED

Application for Amendment of Plan under Section 12A for the Town Planning Ordinance (Cap. 131) for Mixed Use Development at Lot 796 and 1008RP in D.D. 77 and Adjoining Government Land in Ping Che, Ta Kwu Ling, New Territories

J5 Sha Tau Kok Road / Lung Ma Road

ROUNDABOUT CALCULATION

PROJECT NO.: 40876
 FILENAME: J5_STKR_LMR.xls
 REFERENCE NO.:
 PREPARED BY: SKL
 CHECKED BY: SLN
 REVIEWED BY: SLN
 DATE: Feb-24

2023 Existing PM

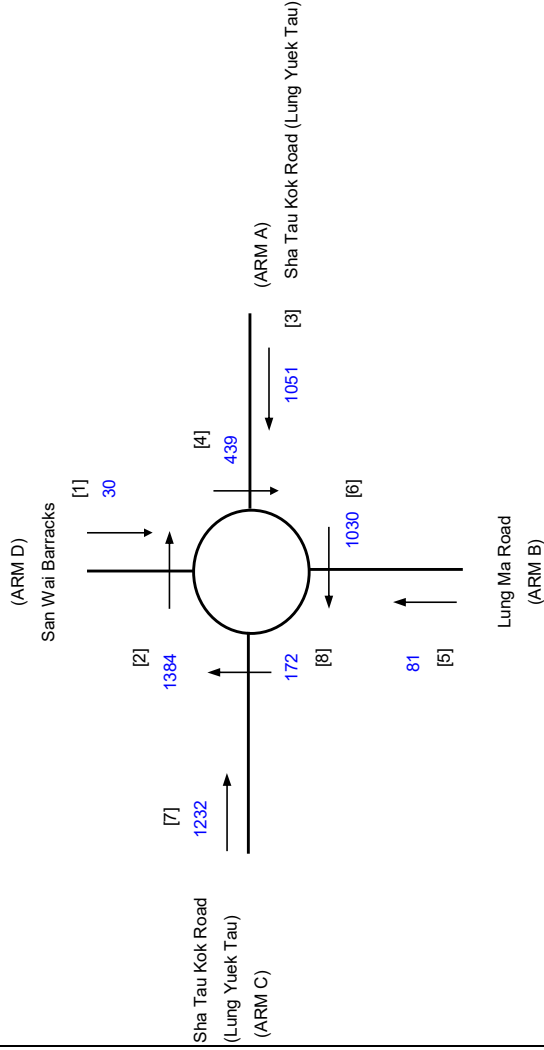

ARM

INPUT PARAMETERS:

	A	B	C	D
V = Approach half width (m)	7.30	3.50	7.30	3.00
E = Entry width (m)	10.00	7.00	9.50	5.00
L = Effective length of flare (m)	11.00	20.00	30.00	15.00
R = Entry radius (m)	20.00	100.00	30.00	35.00
D = Inscribed circle diameter (m)	55.00	55.00	55.00	55.00
A = Entry angle (degree)	20.00	10.00	9.00	15.00
Q = Entry flow (pcu/h)	1051	81	1232	30
Qc = Circulating flow across entry (pcu/h)	439	1030	172	1384

OUTPUT PARAMETERS:

S = Sharpness of flare = $1.6(E-V)/L$	0.39	0.28	0.12	0.21
K = $1-0.00347(A-30)-0.978(1/R-0.05)$	1.03	1.11	1.09	1.07
X2 = $V + ((E-V)/(1+2S))$	8.81	5.74	9.08	4.40
M = $EXP((D-60)/10)$	0.61	0.61	0.61	0.61
F = $303*X2$	2670	1740	2752	1334
Td = $1+(0.5/(1+M))$	1.31	1.31	1.31	1.31
Fc = $0.21*Td(1+0.2*X2)$	0.76	0.59	0.78	0.52
Qe = $K(F-Fc*Qc)$	2417	1254	2852	662

DFC = Design flow/Capacity = Q/Qe

Total In Sum = 2394 PCU

DFC of Critical Approach = 0.43

Appendix B
Junction Capacity Assessments
- Reference & Design Scenarios

LLA CONSULTANCY LIMITED

Application for Amendment of Plan under Section 12A for the Town Planning Ordinance (Cap. 131) for Mixed Use Development at Lot 796 and 1008RP in D.D. 77 and Adjoining Government Land in Ping Che, Ta Kwo Ling, New Territories

J1 Sha Tau Kok Road / Heung Yuen Wai Highway

ROUNDABOUT CALCULATION

PROJECT NO.: 40876
 FILENAME J1_STKR_HYWH.xls
 REFERENCE NO.:
 PREPARED BY: SKL
 CHECKED BY: SLN
 REVIEWED BY: SLN
 DATE: Feb-24

2035 Reference AM

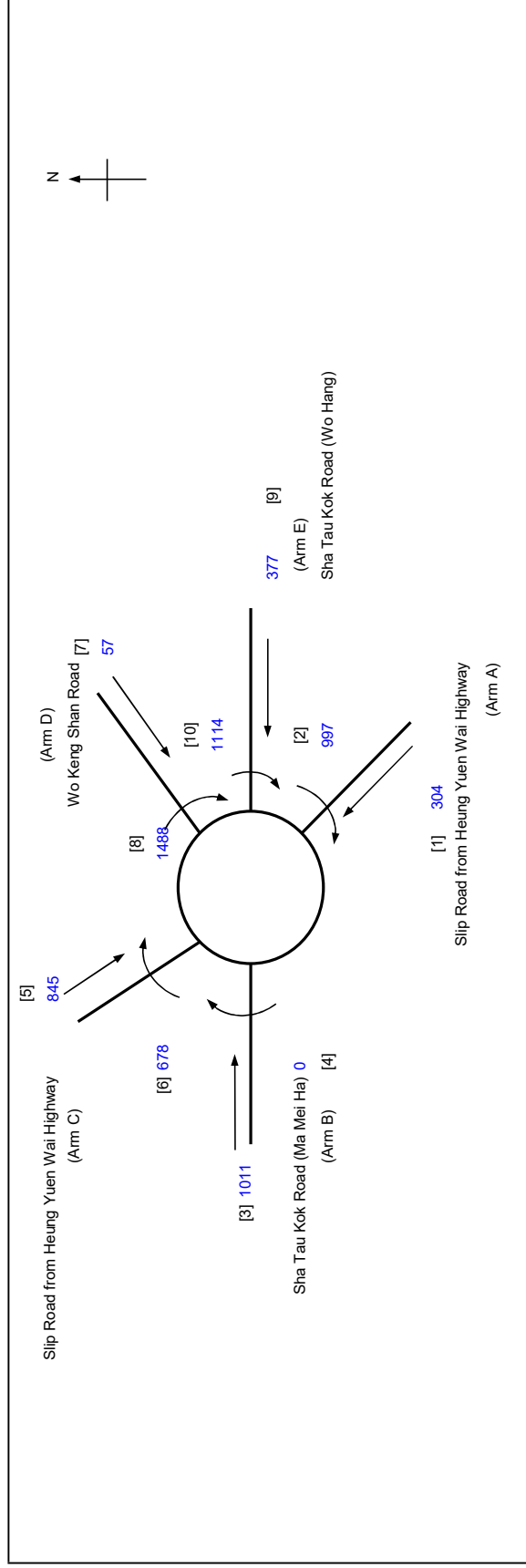

ARM	A	B	C	D	E
V = Approach half width (m)	4.00	3.30	4.00	3.90	3.70
E = Entry width (m)	9.90	7.60	9.80	7.70	7.70
L = Effective length of flare (m)	24.00	33.00	28.00	27.00	35.00
R = Entry radius (m)	60.00	40.00	40.00	44.00	27.00
D = Inscribed circle diameter (m)	50.00	50.00	50.00	50.00	50.00
A = Entry angle (degree)	35.00	35.00	35.00	35.00	10.00
Q = Entry flow (pcu/h)	304	1011	845	57	377
Qc = Circulating flow across entry (pcu/h)	997	0	678	1488	1114
OUTPUT PARAMETERS:					
S = Sharpness of flare = 1.6(E-V)/L	0.39	0.21	0.33	0.23	0.18
K = 1-0.00347(A-30)-0.978(1/R-0.05)	1.02	1.01	1.01	1.01	1.08
X2 = V + ((E-V)/(1+2S))	7.30	6.33	7.49	6.52	6.63
M = EXP((D-60)/10)	0	0	0	0	0
F = 303*X2	2213	1919	2269	1976	2009
Td = 1+(0.5/(1+M))	1.37	1.37	1.37	1.37	1.37
Fc = 0.21*Td(1+0.2*X2)	0.71	0.65	0.72	0.66	0.67
Qe = K(F-Fc*Qc)	1532	1933	1796	1002	1369
DFC = Design flow/Capacity = Q/Qe	0.20	0.52	0.47	0.06	0.28
Total In Sum =					2594 PCU
DFC of Critical Approach =					0.52

LLA CONSULTANCY LIMITED

Job Title: Application for Amendment of Plan under Section 12A for the Town Planning Ordinance (Cap. 131) for Mixed Use Development at Lot 796 and 1008RP in D.D. 77 and Adjoining Government Land in Ping Che, Ta Kwo Ling, New Territories

J1 Sha Tau Kok Road / Heung Yuen Wai Highway

ROUNDABOUT CALCULATION

PROJECT NO.: 40876
 FILENAME J1_STKR_HYWH.xls
 REFERENCE NO.:
 PREPARED BY: SKL
 CHECKED BY: SLN
 REVIEWED BY: SLN
 DATE: Feb-24

2035 Reference PM

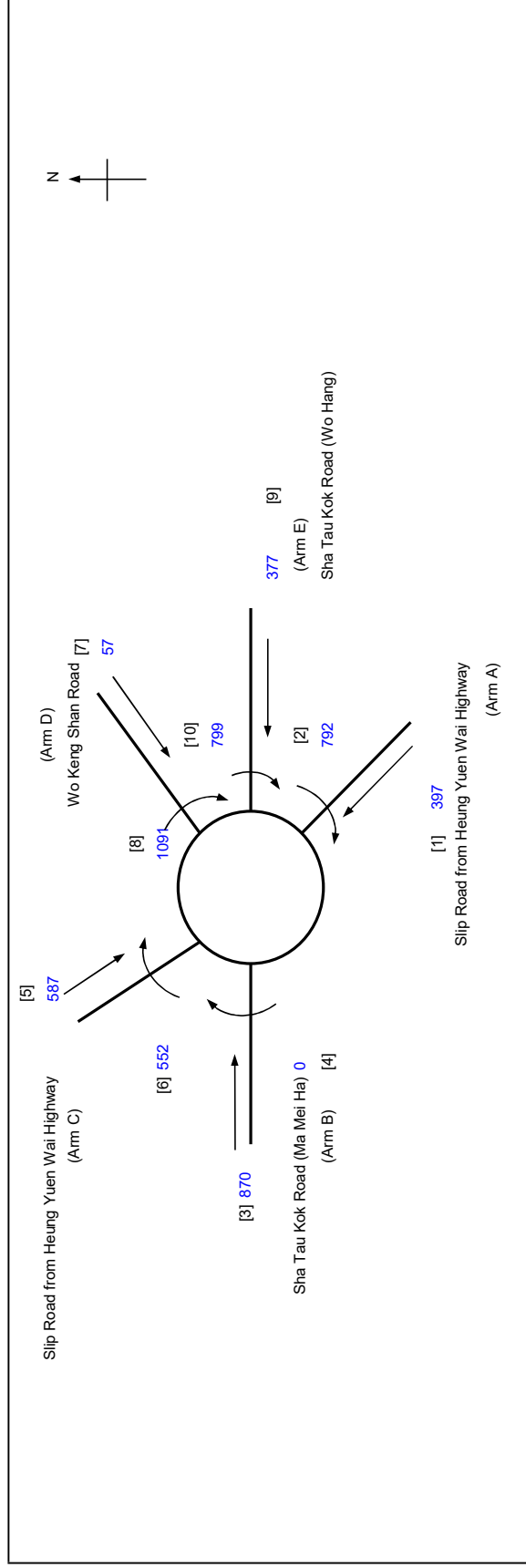

ARM	A	B	C	D	E
V = Approach half width (m)	4.00	3.30	4.00	3.90	3.70
E = Entry width (m)	9.90	7.60	9.80	7.70	7.70
L = Effective length of flare (m)	24.00	33.00	28.00	27.00	35.00
R = Entry radius (m)	60.00	40.00	40.00	44.00	27.00
D = Inscribed circle diameter (m)	50.00	50.00	50.00	50.00	50.00
A = Entry angle (degree)	35.00	35.00	35.00	35.00	10.00
Q = Entry flow (pcu/h)	397	870	587	57	377
Qc = Circulating flow across entry (pcu/h)	792	0	552	1091	799
OUTPUT PARAMETERS:					
S = Sharpness of flare = 1.6(E-V)/L	0.39	0.21	0.33	0.23	0.18
K = 1-0.00347(A-30)-0.978(1/R-0.05)	1.02	1.01	1.01	1.01	1.08
X2 = V + ((E-V)/(1+2S))	7.30	6.33	7.49	6.52	6.63
M = EXP((D-60)/10)	0	0	0	0	0
F = 303*X2	2213	1919	2269	1976	2009
Td = 1+(0.5/(1+M))	1.37	1.37	1.37	1.37	1.37
Fc = 0.21*Td(1+0.2*X2)	0.71	0.65	0.72	0.66	0.67
Qe = K(F-Fc*Qc)	1679	1933	1887	1266	1597
DFC = Design flow/Capacity = Q/Qe	0.24	0.45	0.31	0.05	0.24
Total In Sum =					2288 PCU
DFC of Critical Approach =					0.45

LLA CONSULTANCY LIMITED

Job Title: Application for Amendment of Plan under Section 12A for the Town Planning Ordinance (Cap. 131) for Mixed Use Development at Lot 796 and 1008RP in D.D. 77 and Adjoining Government Land in Ping Che, Ta Kwu Ling, New Territories

J1 Sha Tau Kok Road / Heung Yuen Wai Highway

ROUNDABOUT CALCULATION

PROJECT NO.: 40876
 FILENAME J1_STKR_HYWH.xls
 REFERENCE NO.:
 PREPARED BY: SKL
 CHECKED BY: SLN
 REVIEWED BY: SLN
 DATE: Feb-24

2035 Design AM

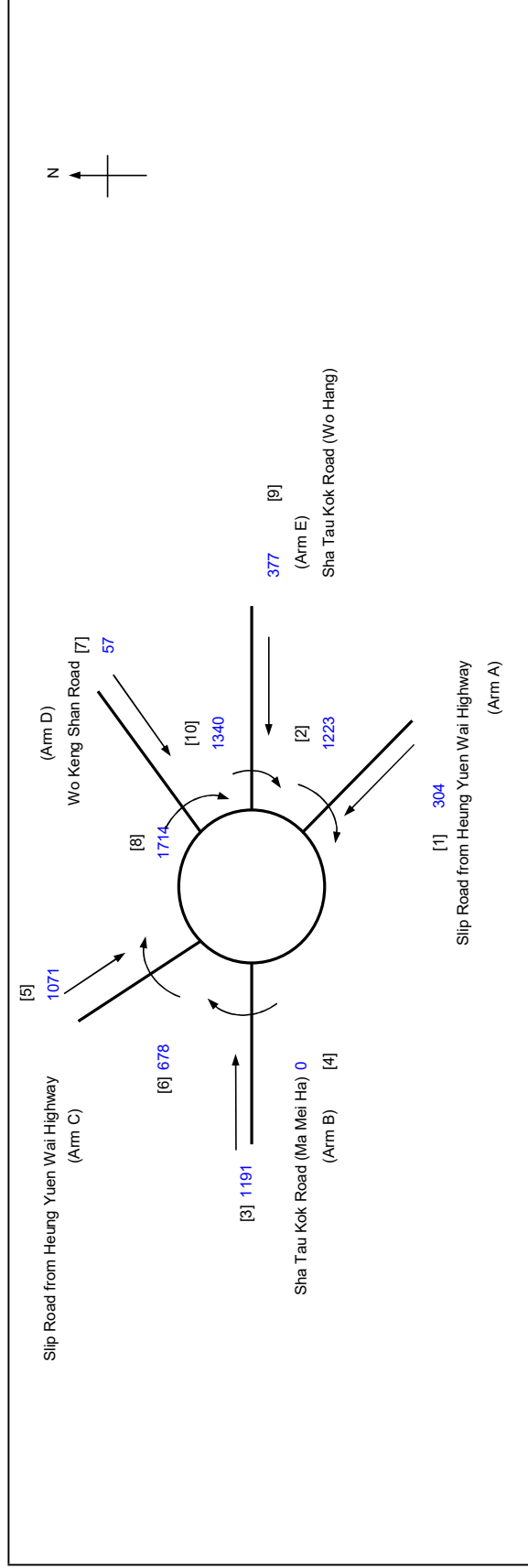

ARM	A	B	C	D	E
V = Approach half width (m)	4.00	3.30	4.00	3.90	3.70
E = Entry width (m)	9.90	7.60	9.80	7.70	7.70
L = Effective length of flare (m)	24.00	33.00	28.00	27.00	35.00
R = Entry radius (m)	60.00	40.00	40.00	44.00	27.00
D = Inscribed circle diameter (m)	50.00	50.00	50.00	50.00	50.00
A = Entry angle (degree)	35.00	35.00	35.00	35.00	10.00
Q = Entry flow (pcu/h)	304	1191	1071	57	377
Qc = Circulating flow across entry (pcu/h)	1223	0	678	1714	1340
OUTPUT PARAMETERS:					
S = Sharpness of flare = 1.6(E-V)/L	0.39	0.21	0.33	0.23	0.18
K = 1-0.00347(A-30)-0.978(1/R-0.05)	1.02	1.01	1.01	1.01	1.08
X2 = V + ((E-V)/(1+2S))	7.30	6.33	7.49	6.52	6.63
M = EXP(-(D-60)/10)	0	0	0	0	0
F = 303*X2	2213	1919	2269	1976	2009
Td = 1+(0.5/(1+M))	1.37	1.37	1.37	1.37	1.37
Fc = 0.21*Td(1+0.2*X2)	0.71	0.65	0.72	0.66	0.67
Qe = K(F-Fc*Qc)	1370	1933	1796	851	1206
DFC = Design flow/Capacity = Q/Qe	0.22	0.62	0.60	0.07	0.31
Total In Sum =					3000 PCU
DFC of Critical Approach =					0.62

LLA CONSULTANCY LIMITED

Job Title: Application for Amendment of Plan under Section 12A for the Town Planning Ordinance (Cap. 131) for Mixed Use Development at Lot 796 and 1008RP in D.D. 77 and Adjoining Government Land in Ping Che, Ta Kwu Ling, New Territories

J1 Sha Tau Kok Road / Heung Yuen Wai Highway

ROUNDABOUT CALCULATION

PROJECT NO.: 40876
 FILENAME J1_STKR_HYWH.xls
 REFERENCE NO.:
 PREPARED BY: SKL
 CHECKED BY: SLN
 REVIEWED BY: SLN
 DATE: Feb-24

2035 Design PM

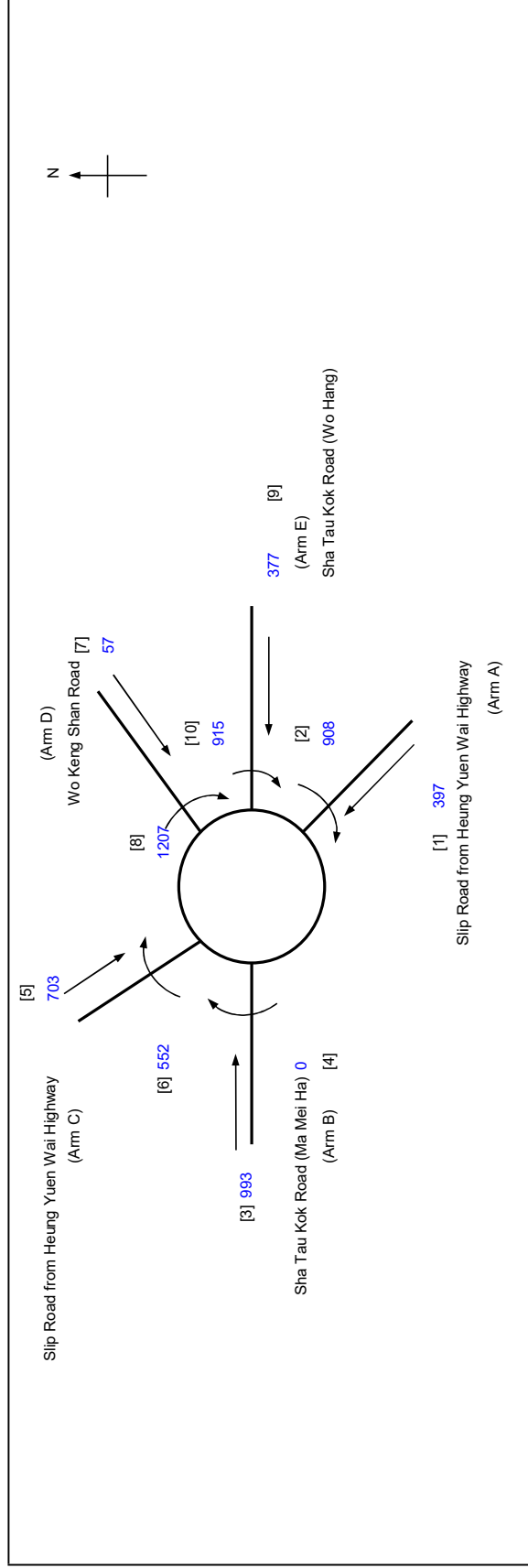

ARM	A	B	C	D	E
V = Approach half width (m)	4.00	3.30	4.00	3.90	3.70
E = Entry width (m)	9.90	7.60	9.80	7.70	7.70
L = Effective length of flare (m)	24.00	33.00	28.00	27.00	35.00
R = Entry radius (m)	60.00	40.00	40.00	44.00	27.00
D = Inscribed circle diameter (m)	50.00	50.00	50.00	50.00	50.00
A = Entry angle (degree)	35.00	35.00	35.00	35.00	10.00
Q = Entry flow (pcu/h)	397	993	703	57	377
Qc = Circulating flow across entry (pcu/h)	908	0	552	1207	915
OUTPUT PARAMETERS:					
S = Sharpness of flare = 1.6(E-V)/L	0.39	0.21	0.33	0.23	0.18
K = 1-0.00347(A-30)-0.978(1/R-0.05)	1.02	1.01	1.01	1.01	1.08
X2 = V + ((E-V)/(1+2S))	7.30	6.33	7.49	6.52	6.63
M = EXP((D-60)/10)	0	0	0	0	0
F = 303*X2	2213	1919	2269	1976	2009
Td = 1+(0.5/(1+M))	1.37	1.37	1.37	1.37	1.37
Fc = 0.21*Td(1+0.2*X2)	0.71	0.65	0.72	0.66	0.67
Qe = K(F-Fc*Qc)	1596	1933	1887	1189	1513
DFC = Design flow/Capacity = Q/Qe	0.25	0.51	0.37	0.05	0.25
Total In Sum =					2527 PCU
DFC of Critical Approach =					0.51

LLA CONSULTANCY LIMITED

Job Title: Application for Amendment of Plan under Section 12A for the Town Planning Ordinance (Cap. 131) for Mixed Use Development at Lot 796 and 1008RP in D.D. 77 and Adjoining Government Land in Ping Che, Ta Kwu Ling, New Territories

J2 Sha Tau Kok Road / Ping Che Road

ROUNDABOUT CALCULATION

2035 Reference AM

PROJECT NO.: 40876

FILENAME: J2_STKR_PCR.xlsx

REFERENCE NO.:

PREPARED BY:

CHECKED BY:

REVIEWED BY:

INITIALS

DATE

SKL
Feb-24

SLN
Feb-24

SLN
Feb-24

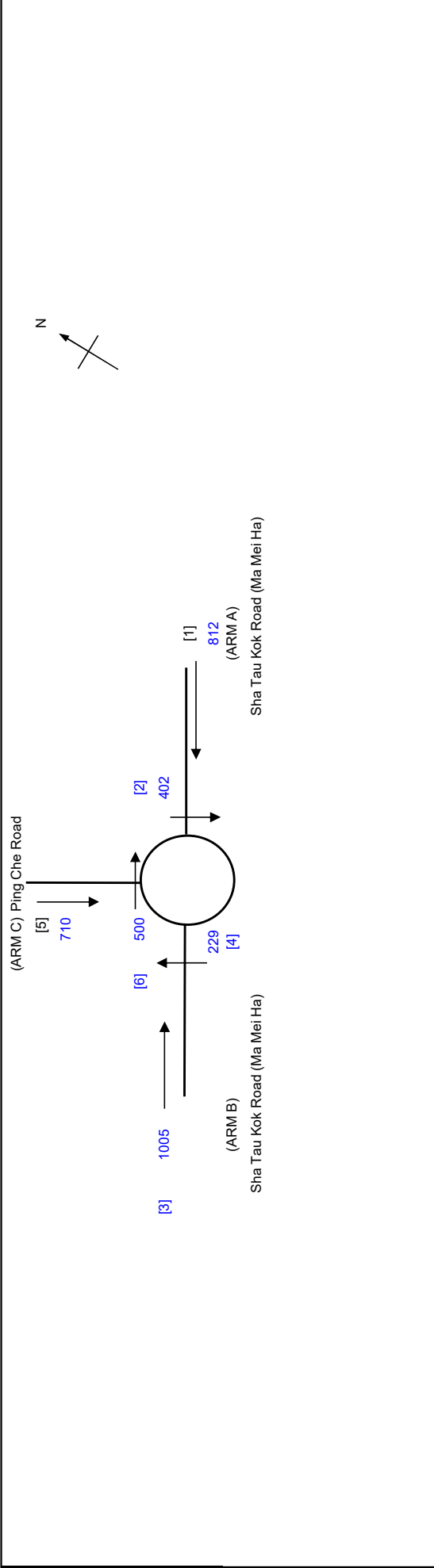

ARM

INPUT PARAMETERS:

	A	B	C
V = Approach half width (m)	7.40	7.30	4.10
E = Entry width (m)	8.20	7.90	8.10
L = Effective length of flare (m)	1.00	1.00	5.00
R = Entry radius (m)	75.00	60.00	40.00
D = Inscribed circle diameter (m)	53.00	53.00	53.00
A = Entry angle (degree)	10.00	15.00	10.00
Q = Entry flow (pcu/h)	812	1005	710
Qc = Circulating flow across entry (pcu/h)	402	229	500

OUTPUT PARAMETERS:

S = Sharpness of flare = 1.6(E-V)/L	1.28	0.96	1.28
K = 1-0.00347(A-30)-0.978(1/R-0.05)	1.11	1.08	1.09
X2 = V + ((E-V)/(1+2S))	7.62	7.51	5.22
M = EXP((D-60)/10)	0.50	0.50	0.50
F = 303*X2	2310	2274	1583
Td = 1+(0.5/(1+M))	1.33	1.33	1.33
Fc = 0.21*Td(1+0.2*X2)	0.71	0.70	0.57
Qe = K(F-Fc*Qc)	2239	2293	1418

DFC = Design flow/Capacity = Q/Qe

0.36 0.44 0.50

Total In Sum =

3658 PCU

DFC of Critical Approach =

0.50

LLA CONSULTANCY LIMITED

Job Title: Application for Amendment of Plan under Section 12A for the Town Planning Ordinance (Cap. 131) for Mixed Use Development at Lot 796 and 1008RP in D.D. 77 and Adjoining Government Land in Ping Che, Ta Kwu Ling, New Territories

J2 Sha Tau Kok Road / Ping Che Road

ROUNDABOUT CALCULATION

2035 Reference PM

PROJECT NO.: 40876

FILENAME: J2_STKR_PCR.xlsx

REFERENCE NO.:

INITIALS

PREPARED BY:

CHECKED BY:

REVIEWED BY:

DATE

Feb-24

Feb-24

Feb-24

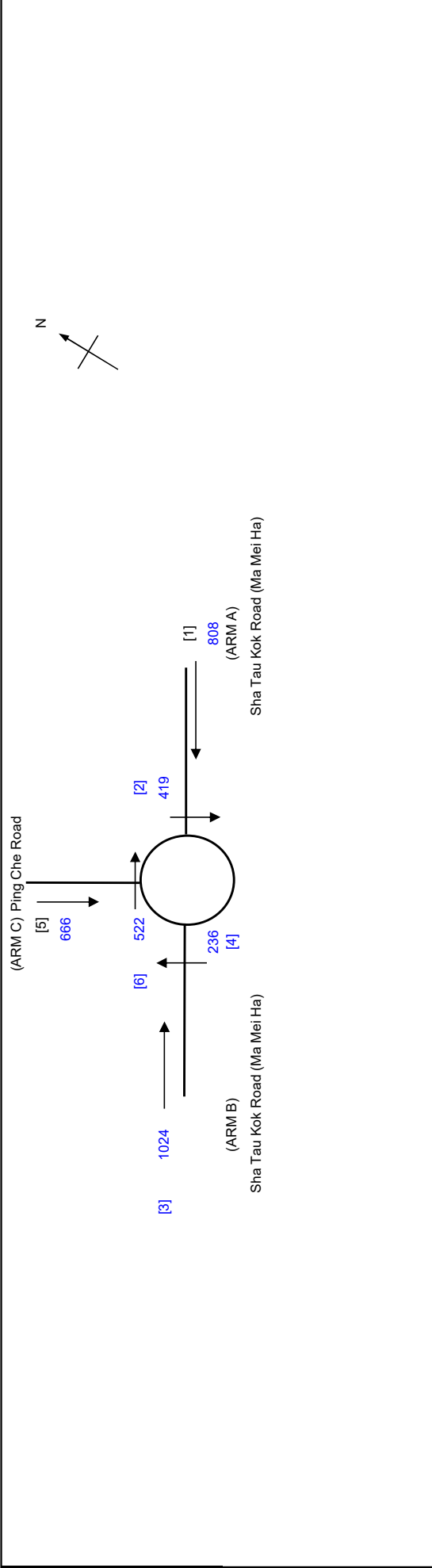

ARM	A	B	C
INPUT PARAMETERS:			
V = Approach half width (m)	7.40	7.30	4.10
E = Entry width (m)	8.20	7.90	8.10
L = Effective length of flare (m)	1.00	1.00	5.00
R = Entry radius (m)	75.00	60.00	40.00
D = Inscribed circle diameter (m)	53.00	53.00	53.00
A = Entry angle (degree)	10.00	15.00	10.00
Q = Entry flow (pcu/h)	808	1024	666
Qc = Circulating flow across entry (pcu/h)	419	236	522
OUTPUT PARAMETERS:			
S = Sharpness of flare = 1.6(E-V)/L	1.28	0.96	1.28
K = 1-0.00347(A-30)+0.978(1/R-0.05)	1.11	1.08	1.09
X2 = V + ((E-V)/(1+2S))	7.62	7.51	5.22
M = EXP((D-60)/10)	0.50	0.50	0.50
F = 303*X2	2310	2274	1583
Td = 1+(0.5/(1+M))	1.33	1.33	1.33
Fc = 0.21*Td(1+0.2*X2)	0.71	0.70	0.57
Qe = K(F-Fc*Qc)	2226	2287	1404
DFC = Design flow/Capacity = Q/Qe	0.36	0.45	0.47
Total In Sum =			3675 PCU
DFC of Critical Approach =			0.47

LLA CONSULTANCY LIMITED

Job Title: Application for Amendment of Plan under Section 12A for the Town Planning Ordinance (Cap. 131) for Mixed Use Development at Lot 796 and 1008RP in D.D. 77 and Adjoining Government Land in Ping Che, Ta Kwu Ling, New Territories

J2 Sha Tau Kok Road / Ping Che Road

ROUNDABOUT CALCULATION

PROJECT NO.: 40876
 FILENAME: J2_STKR_PCR.xlsx
 REFERENCE NO.:

PREPARED BY: SKL
 CHECKED BY: SLN
 REVIEWED BY: SLN
 DATE: Feb-24

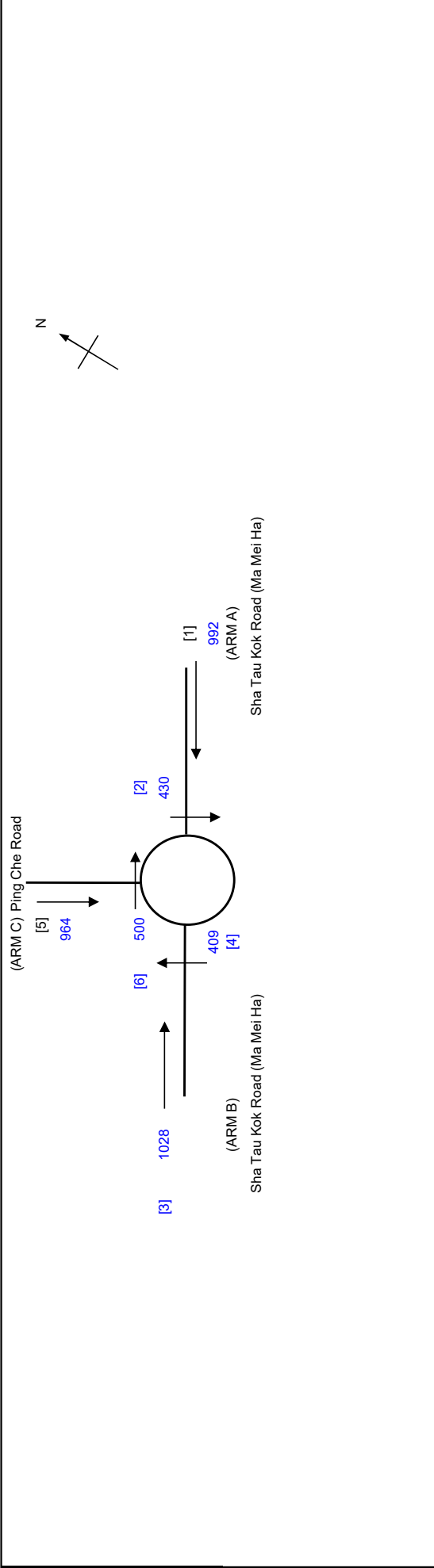

	A	B	C
INPUT PARAMETERS:			
V = Approach half width (m)	7.40	7.30	4.10
E = Entry width (m)	8.20	7.90	8.10
L = Effective length of flare (m)	1.00	1.00	5.00
R = Entry radius (m)	75.00	60.00	40.00
D = Inscribed circle diameter (m)	53.00	53.00	53.00
A = Entry angle (degree)	10.00	15.00	10.00
Q = Entry flow (pcu/h)	992	1028	964
Qc = Circulating flow across entry (pcu/h)	430	409	500
OUTPUT PARAMETERS:			
S = Sharpness of flare = 1.6(E-V)/L	1.28	0.96	1.28
K = 1-0.00347(A-30)-0.978(1/R-0.05)	1.11	1.08	1.09
X2 = V + ((E-V)/(1+2S))	7.62	7.51	5.22
M = EXP((D-60)/10)	0.50	0.50	0.50
F = 303*X2	2310	2274	1583
Td = 1+(0.5/(1+M))	1.33	1.33	1.33
Fc = 0.21*Td(1+0.2*X2)	0.71	0.70	0.57
Qe = K(F-Fc*Qc)	2217	2156	1418
DFC = Design flow/Capacity = Q/Qe	0.45	0.48	0.68

Total In Sum = 4323 PCU

DFC of Critical Approach = 0.68

LLA CONSULTANCY LIMITED

Job Title: Application for Amendment of Plan under Section 12A for the Town Planning Ordinance (Cap. 131) for Mixed Use Development at Lot 796 and 1008RP in D.D. 77 and Adjoining Government Land in Ping Che, Ta Kwu Ling, New Territories

J2 Sha Tau Kok Road / Ping Che Road

ROUNDABOUT CALCULATION

2035 Design PM

PROJECT NO.: 40876

FILENAME: J2_STKR_PCR.xlsx

REFERENCE NO.:

INITIALS

PREPARED BY:

CHECKED BY:

REVIEWED BY:

DATE

Feb-24

Feb-24

Feb-24

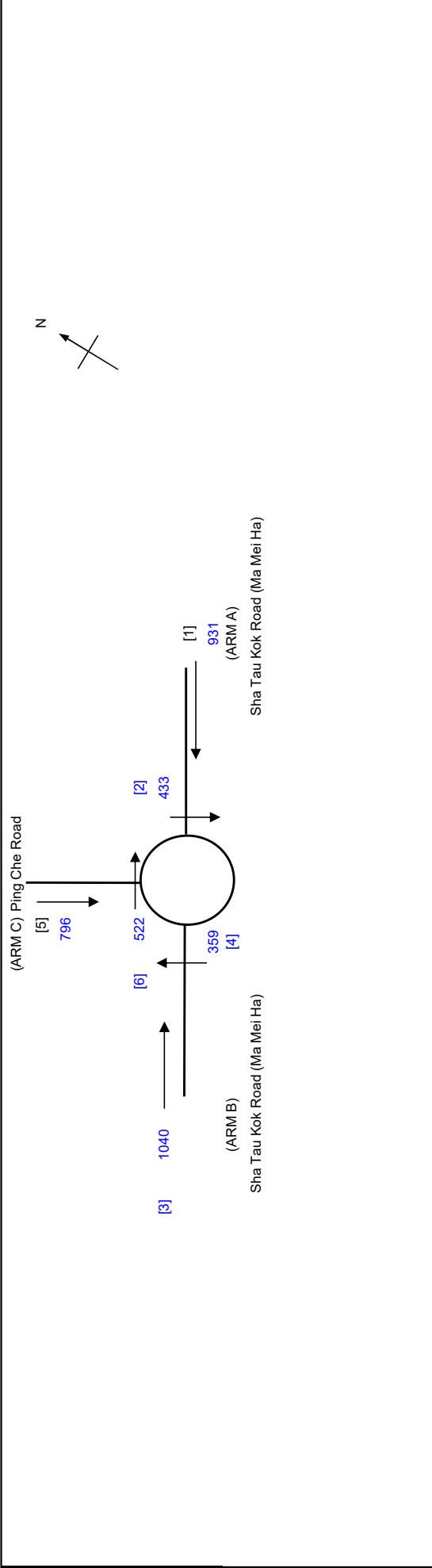

ARM

INPUT PARAMETERS:

Parameter	A	B	C
V = Approach half width (m)	7.40	7.30	4.10
E = Entry width (m)	8.20	7.90	8.10
L = Effective length of flare (m)	1.00	1.00	5.00
R = Entry radius (m)	75.00	60.00	40.00
D = Inscribed circle diameter (m)	53.00	53.00	53.00
A = Entry angle (degree)	10.00	15.00	10.00
Q = Entry flow (pcu/h)	931	1040	796
Qc = Circulating flow across entry (pcu/h)	433	359	522

OUTPUT PARAMETERS:

S = Sharpness of flare = $1.6(E-V)/L$	1.28	0.96	1.28
K = $1-0.00347(A-30)+0.978(1/R-0.05)$	1.11	1.08	1.09
X2 = $V + ((E-V)/(1+2S))$	7.62	7.51	5.22
M = $EXP((D-60)/10)$	0.50	0.50	0.50
F = $303 \times X2$	2310	2274	1583
Td = $1+(0.5/(1+M))$	1.33	1.33	1.33
Fc = $0.21 \times Td(1+0.2 \times X2)$	0.71	0.70	0.57
Qe = $K(F-Fc)Qc$	2215	2194	1404

DFC = Design flow/Capacity = Q/Qe

Total In Sum =

4081 PCU

DFC of Critical Approach =

0.57

LLA CONSULTANCY LIMITED

Job Application for Amendment of Plan under Section 12A for the Town Planning Ordinance (Cap. 131) for Mixed Use Development at Lot 796 and 1008RP in D.D. 77 and Adjoining Government Land in Ping Che, Ta Kwu Ling, New Territories

J3 Sha Tau Kok Road / Lau Shui Heung Road

ROUNDABOUT CALCULATION

PROJECT NO.: 40876
 FILENAME: J3_STKR_LSHR.x
 REFERENCE NO.:
 PREPARED BY: SKL
 CHECKED BY: SLN
 REVIEWED BY: SLN
 DATE: Feb-24

2035 Reference AM

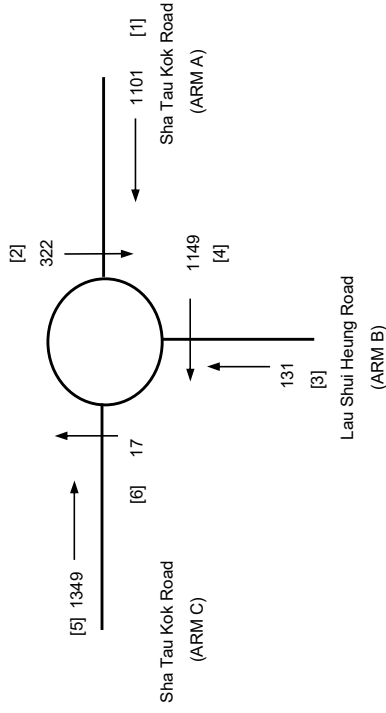

ARM

INPUT PARAMETERS:

	A	B	C
V = Approach half width (m)	6.30	3.60	6.60
E = Entry width (m)	6.90	5.60	7.00
L = Effective length of flare (m)	1.00	7.00	1.00
R = Entry radius (m)	80.00	110.00	16.00
D = Inscribed circle diameter (m)	53.00	53.00	53.00
A = Entry angle (degree)	15.00	15.00	15.00
Q = Entry flow (pcu/h)	1101	131	1349
Qc = Circulating flow across entry (pcu/h)	322	1149	17

OUTPUT PARAMETERS:

S = Sharpness of flare = $1.6(E-V)/L$	0.96	0.46	0.64
K = $1-0.00347(A-30)-0.978(1/R-0.05)$	1.09	1.09	1.04
X2 = $V + ((E-V)/(1+2S))$	6.51	4.64	6.78
M = $EXP((D-60)/10)$	0.50	0.50	0.50
F = $303 \times X2$	1971	1407	2053
Td = $1+(0.5/(1+M))$	1.33	1.33	1.33
Fc = $0.21 \times Td(1+0.2 \times X2)$	0.64	0.54	0.66
Qe = $K(F-Fc \times Qc)$	1920	859	2123

DFC = Design flow/Capacity = Q/Qe

0.57 0.15 0.64

Total In Sum =

2581 PCU

DFC of Critical Approach = 0.64

LLA CONSULTANCY LIMITED

Job Application for Amendment of Plan under Section 12A for the Town Planning Ordinance (Cap. 131) for Mixed Use Development at Lot 796 and 1008RP in D.D. 77 and Adjoining Government Land in Ping Che, Ta Kwu Ling, New Territories

J3 Sha Tau Kok Road / Lau Shui Heung Road

ROUNDABOUT CALCULATION

PROJECT NO.: 40876
 FILENAME: J3_STKR_LSHR.x
 REFERENCE NO.:
 PREPARED BY: SKL
 CHECKED BY: SLN
 REVIEWED BY: SLN
 DATE: Feb-24

2035 Reference PM



ARM	A	B	C
V = Approach half width (m)	6.30	3.60	6.60
E = Entry width (m)	6.90	5.60	7.00
L = Effective length of flare (m)	1.00	7.00	1.00
R = Entry radius (m)	80.00	110.00	16.00
D = Inscribed circle diameter (m)	53.00	53.00	53.00
A = Entry angle (degree)	15.00	15.00	15.00
Q = Entry flow (pcu/h)	1048	156	1421
Qc = Circulating flow across entry (pcu/h)	397	1164	29
OUTPUT PARAMETERS:			
S = Sharpness of flare = 1.6(E-V)/L	0.96	0.46	0.64
K = 1-0.00347(A-30)-0.978(1/R-0.05)	1.09	1.09	1.04
X2 = V + ((E-V)/(1+2S))	6.51	4.64	6.78
M = EXP((D-60)/10)	0.50	0.50	0.50
F = 303*X2	1971	1407	2053
Td = 1+(0.5/(1+M))	1.33	1.33	1.33
Fc = 0.21*Td(1+0.2*X2)	0.64	0.54	0.66
Qe = K(F-Fc*Qc)	1867	850	2115
DFC = Design flow/Capacity = Q/Qe	0.56	0.18	0.67
Total In Sum =			2625 PCU
DFC of Critical Approach =			0.67

LLA CONSULTANCY LIMITED

Job Application for Amendment of Plan under Section 12A for the Town Planning Ordinance (Cap. 131) for Mixed Use Development at Lot 796 and 1008RP in D.D. 77 and Adjoining Government Land in Ping Che, Ta Kwu Ling, New Territories

J3 Sha Tau Kok Road / Lau Shui Heung Road

ROUNDABOUT CALCULATION

PROJECT NO.: 40876
 FILENAME: J3_STKR_LSHR.x
 REFERENCE NO.:
 PREPARED BY: SKL
 CHECKED BY: SLN
 REVIEWED BY: SLN
 DATE: Feb-24

2035 Design AM

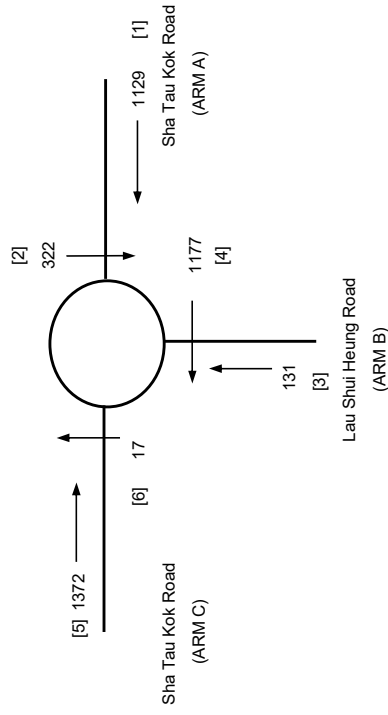

ARM

INPUT PARAMETERS:

	A	B	C
V = Approach half width (m)	6.30	3.60	6.60
E = Entry width (m)	6.90	5.60	7.00
L = Effective length of flare (m)	1.00	7.00	1.00
R = Entry radius (m)	80.00	110.00	16.00
D = Inscribed circle diameter (m)	53.00	53.00	53.00
A = Entry angle (degree)	15.00	15.00	15.00
Q = Entry flow (pcu/h)	1129	131	1372
Qc = Circulating flow across entry (pcu/h)	322	1177	17

OUTPUT PARAMETERS:

S = Sharpness of flare = $1.6(E-V)/L$	0.96	0.46	0.64
K = $1-0.00347(A-30)-0.978(1/R-0.05)$	1.09	1.09	1.04
X2 = $V + ((E-V)/(1+2S))$	6.51	4.64	6.78
M = $EXP((D-60)/10)$	0.50	0.50	0.50
F = $303 \times X2$	1971	1407	2053
Td = $1+(0.5/(1+M))$	1.33	1.33	1.33
Fc = $0.21 \times Td(1+0.2 \times X2)$	0.64	0.54	0.66
Qe = $K(F-Fc \times Qc)$	1920	842	2123

DFC = Design flow/Capacity = Q/Qe

Total In Sum =

2632 PCU

DFC of Critical Approach = 0.65

LLA CONSULTANCY LIMITED

Job Application for Amendment of Plan under Section 12A for the Town Planning Ordinance (Cap. 131) for Mixed Use Development at Lot 796 and 1008RP in D.D. 77 and Adjoining Government Land in Ping Che, Ta Kwu Ling, New Territories

J3 Sha Tau Kok Road / Lau Shui Heung Road

ROUNDABOUT CALCULATION

PROJECT NO.: 40876
 FILENAME: J3_STKR_LSHR.x
 REFERENCE NO.:
 PREPARED BY: SKL
 CHECKED BY: SLN
 REVIEWED BY: SLN
 DATE: Feb-24

2035 Design PM

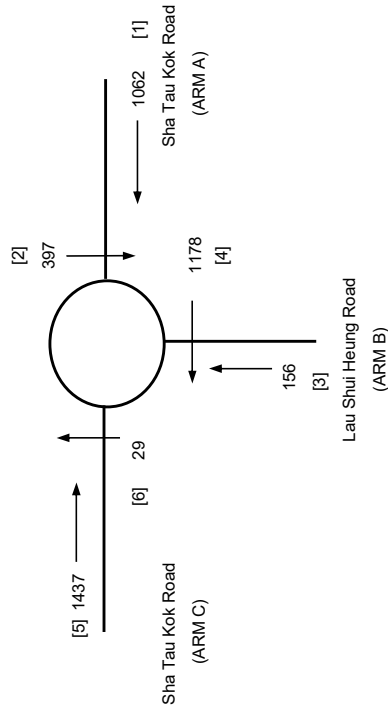

ARM

INPUT PARAMETERS:

	A	B	C
V = Approach half width (m)	6.30	3.60	6.60
E = Entry width (m)	6.90	5.60	7.00
L = Effective length of flare (m)	1.00	7.00	1.00
R = Entry radius (m)	80.00	110.00	16.00
D = Inscribed circle diameter (m)	53.00	53.00	53.00
A = Entry angle (degree)	15.00	15.00	15.00
Q = Entry flow (pcu/h)	1062	156	1437
Qc = Circulating flow across entry (pcu/h)	397	1178	29

OUTPUT PARAMETERS:

S = Sharpness of flare = $1.6(E-V)/L$	0.96	0.46	0.64
K = $1-0.00347(A-30)-0.978(1/R-0.05)$	1.09	1.09	1.04
X2 = $V + ((E-V)/(1+2S))$	6.51	4.64	6.78
M = $EXP((D-60)/10)$	0.50	0.50	0.50
F = $303 \times X2$	1971	1407	2053
Td = $1+(0.5/(1+M))$	1.33	1.33	1.33
Fc = $0.21 \times Td(1+0.2 \times X2)$	0.64	0.54	0.66
Qe = $K(F-Fc \times Qc)$	1867	842	2115

DFC = Design flow/Capacity = Q/Qe

Total In Sum = 2655 PCU

DFC of Critical Approach = 0.68

LLA CONSULTANCY LIMITED

Application for Amendment of Plan under Section 12A for the Town Planning Ordinance (Cap. 131) for Mixed Use Development at Lot 796 and 1008RP in D.D. 77 and Adjoining Government Land in Ping Che, Ta Kwu Ling, New Territories

PRIORITY JUNCTION CALCULATION

2035 Reference AM

PROJECT NO.: 40876
 FILENAME: J4_PCR_NCR.xlsx
 REFERENCE NO.:

INITIALS: SKL
 PREPARED BY: SKL
 CHECKED BY: SLN
 REVIEWED BY: SLN

DATE: Feb-24
 Feb-24
 Feb-24

J4 Ping Che Road / Ng Chow Road

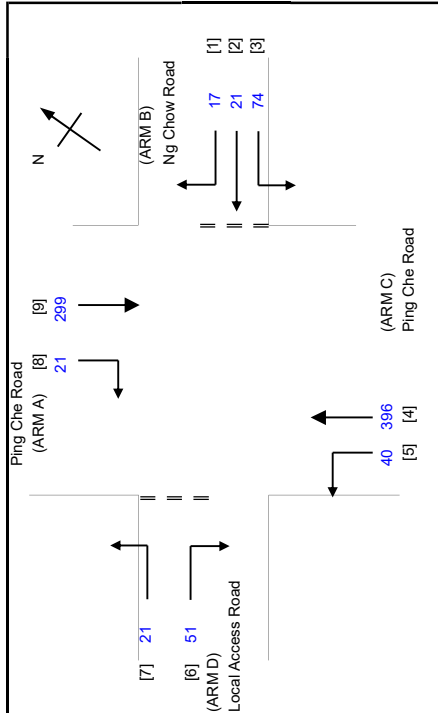

NOTES : (GEOMETRIC INPUT DATA)

- W = MAJOR ROAD WIDTH
- W cr = CENTRAL RESERVE WIDTH
- W b-a = LANE WIDTH AVAILABLE TO VEHICLE WAITING IN STREAM b-a
- W b-c = LANE WIDTH AVAILABLE TO VEHICLE WAITING IN STREAM b-c
- W c-b = LANE WIDTH AVAILABLE TO VEHICLE WAITING IN STREAM c-b
- Vi b-a = VISIBILITY TO THE LEFT FOR VEHICLES WAITING IN STREAM b-a
- Vi b-c = VISIBILITY TO THE RIGHT FOR VEHICLES WAITING IN STREAM b-a
- Vi c-b = VISIBILITY TO THE RIGHT FOR VEHICLES WAITING IN STREAM b-c
- X a = STREAM-SPECIFIC (RIGHT TURN FROM A)
- X b = STREAM-SPECIFIC (RIGHT TURN FROM B)
- Z b = STREAM-SPECIFIC (LEFT TURN FROM B)
- M b = STREAM-SPECIFIC (STRAIGHT AHEAD FROM B - LEFT LANE)
- Y = (1-0.0345W)
- r b-a = RATIO OF FLOW TO CAPACITY IN STREAM b-a

GEOMETRIC DETAILS:

GENERAL					
W	=	7.30	(metres)		
W cr	=	0	(metres)	Y	= 0.748
MAJOR ROAD (ARM A)					
W a-d	=	3.65	(metres)	W c-b	= 0.00 (metres)
Vr a-d	=	100	(metres)	Vr c-b	= 0 (metres)
q a-b	=	0	(pcu/hr)	q c-a	= 396 (pcu/hr)
q a-c	=	299	(pcu/hr)	q c-b	= 0 (pcu/hr)
q a-d	=	21	(pcu/hr)	q c-d	= 40 (pcu/hr)
MINOR ROAD (ARM B)					
W b-a	=	0.00	(metres)	W d-c	= 3.40 (metres)
W b-c	=	5.00	(metres)	W d-a	= 0.00 (metres)
Vi b-a	=	30	(metres)	Vr d-c	= 18 (metres)
Vi b-c	=	18	(metres)	Vr d-a	= 19 (metres)
q b-a	=	17	(pcu/hr)	q d-c	= 51 (pcu/hr)
q b-c	=	74	(pcu/hr)	q d-a	= 21 (pcu/hr)
q b-d	=	21	(pcu/hr)	q d-b	= 0 (pcu/hr)

GEOMETRIC FACTORS :

X b	=	0.554	X a	=	0.982
X c	=	0.586	X d	=	0.817
Z b	=	1.023	Z d	=	0.597
M b	=	0.950	M d	=	0.550
PROPORTION OF MINOR STRAIGHT AHEAD TRAFFIC :					
r b-a	=	0.0487	r d-c	=	0.146
ql b-d	=	11.011	ql d-b	=	0 (pcu/hr)
qr b-d	=	9.9885	qr d-b	=	0 (pcu/hr)
CAPACITY OF MOVEMENT :					
Q b-a	=	254	(pcu/hr)	Q d-c	= 349 (pcu/hr)
Q b-c	=	671	(pcu/hr)	Q d-a	= 364 (pcu/hr)
Q c-b	=	384	(pcu/hr)	Q a-d	= 615 (pcu/hr)
Ql b-d	=	442	(pcu/hr)	Ql d-b	= 250 (pcu/hr)
Qr b-d	=	258	(pcu/hr)	Qr d-b	= 372 (pcu/hr)
Q b-acc	=	431	(pcu/hr)	Q d-abc	= 353 (pcu/hr)
				TOTAL FLOW =	940 (PCU/HR)

COMPARISON OF DESIGN FLOW TO CAPACITY:

DFC b-a	=	0.0669
DFC b-c	=	0.1103
DFC c-b	=	0.0000
DFCI b-d	=	0.0249
DFCr b-d	=	0.0387
DFC d-c	=	0.1461
DFC d-a	=	0.0577
DFC a-d	=	0.0341
DFCI d-b	=	0.0000
DFCr d-b	=	0.0000
DFC b-acc (shared lane)	=	0.2599
DFC d-abc (shared lane)	=	0.2038

CRITICAL DFC = 0.26

LLA CONSULTANCY LIMITED

Application for Amendment of Plan under Section 12A for the Town Planning Ordinance (Cap. 131) for Mixed Use Development at Lot 796 and 1008RP in D.D. 77 and Adjoining Government Land in Ping Che, Ta Kwu Ling, New Territories

PRIORITY JUNCTION CALCULATION

2035 Reference PM

PROJECT NO.: 40876
 FILENAME: J4_PCR_NCR.xlsx
 REFERENCE NO.:

INITIALS: SKL
 DATE: Feb-24
 PREPARED BY: SKL
 CHECKED BY: SLN
 REVIEWED BY: SLN

J4 Ping Che Road / Ng Chow Road

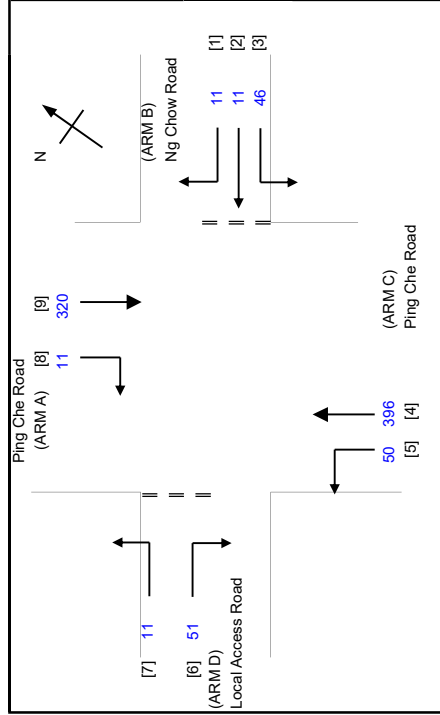

NOTES : (GEOMETRIC INPUT DATA)

- W = MAJOR ROAD WIDTH
- W cr = CENTRAL RESERVE WIDTH
- W b-a = LANE WIDTH AVAILABLE TO VEHICLE WAITING IN STREAM b-a
- W b-c = LANE WIDTH AVAILABLE TO VEHICLE WAITING IN STREAM b-c
- W c-b = LANE WIDTH AVAILABLE TO VEHICLE WAITING IN STREAM c-b
- V i b-a = VISIBILITY TO THE LEFT FOR VEHICLES WAITING IN STREAM b-a
- V r b-a = VISIBILITY TO THE RIGHT FOR VEHICLES WAITING IN STREAM b-a
- V r b-c = VISIBILITY TO THE RIGHT FOR VEHICLES WAITING IN STREAM b-c
- V r c-b = VISIBILITY TO THE LEFT FOR VEHICLES WAITING IN STREAM c-b
- X a = STREAM-SPECIFIC (RIGHT TURN FROM A)
- X b = STREAM-SPECIFIC (RIGHT TURN FROM B)
- Z b = STREAM-SPECIFIC (LEFT TURN FROM B)
- M b = STREAM-SPECIFIC (STRAIGHT AHEAD FROM B - LEFT LANE)
- Y = (1-0.0345W)
- r b-a = RATIO OF FLOW TO CAPACITY IN STREAM b-a

GEOMETRIC DETAILS:

GENERAL				
W	=	7.30	(metres)	
W cr	=	0	(metres)	Y = 0.748
MAJOR ROAD (ARM A)				
W a-d	=	3.65	(metres)	MAJOR ROAD (ARM C)
V r a-d	=	100	(metres)	W c-b = 0.00
q a-b	=	0	(pcu/hr)	V r c-b = 0
q a-c	=	320	(pcu/hr)	q c-a = 396
q a-d	=	11	(pcu/hr)	q c-b = 0
				q c-d = 50
MINOR ROAD (ARM B)				
W b-a	=	0.00	(metres)	MINOR ROAD (ARM D)
W b-c	=	5.00	(metres)	W d-c = 3.40
V i b-a	=	30	(metres)	W d-a = 0.00
V r b-a	=	18	(metres)	V r d-c = 18
V r b-c	=	18	(metres)	V r d-a = 19
q b-a	=	11	(pcu/hr)	q d-c = 51
q b-c	=	46	(pcu/hr)	q d-a = 11
q b-d	=	11	(pcu/hr)	q d-b = 0

GEOMETRIC FACTORS :

X b	=	0.554	X a	=	0.982	
X c	=	0.586	X d	=	0.817	
Z b	=	1.023	Z d	=	0.597	
M b	=	0.950	M d	=	0.550	
PROPORTION OF MINOR STRAIGHT AHEAD TRAFFIC :						
r b-a	=	0.0307	r d-c	=	0.142	
q i b-d	=	5.669	q i d-b	=	0	
q r b-d	=	5.331	q r d-b	=	0	
CAPACITY OF MOVEMENT :						
Q b-a	=	254	(pcu/hr)	Q d-c	=	358
Q b-c	=	668	(pcu/hr)	Q d-a	=	364
Q c-b	=	383	(pcu/hr)	Q a-d	=	612
Q i b-d	=	437	(pcu/hr)	Q i d-b	=	250
Q r b-d	=	255	(pcu/hr)	Q r d-b	=	372
Q b-abc	=	437	(pcu/hr)	Q d-abc	=	359
				TOTAL FLOW =	907	(PCU/HR)

COMPARISON OF DESIGN FLOW TO CAPACITY:

DFC b-a	=	0.0433
DFC b-c	=	0.0689
DFC c-b	=	0.0000
DFCI b-d	=	0.0130
DFCr b-d	=	0.0209
DFC d-c	=	0.1425
DFC d-a	=	0.0302
DFC a-d	=	0.0180
DFCI d-b	=	0.0000
DFCr d-b	=	0.0000
DFC b-acd (shared lane)	=	0.1555
DFC d-abc (shared lane)	=	0.1727

CRITICAL DFC = 0.17

LLA CONSULTANCY LIMITED

Application for Amendment of Plan under Section 12A for the Town Planning Ordinance (Cap. 131) for Mixed Use Development at Lot 796 and 1008RP in D.D. 77 and Adjoining Government Land in Ping Che, Ta Kwu Ling, New Territories

PRIORITY JUNCTION CALCULATION

2035 Design AM

PROJECT NO.: 40876
 FILENAME: J4_PCR_NCR.xlsx
 PREPARED BY: SKL
 CHECKED BY: SLN
 REVIEWED BY: SLN

INITIALS

DATE

Feb-24

Feb-24

Feb-24

J4 Ping Che Road / Ng Chow Road

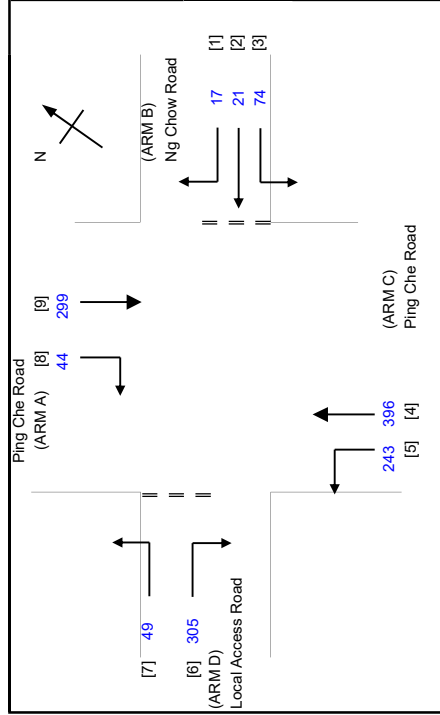

NOTES : (GEOMETRIC INPUT DATA)

- W = MAJOR ROAD WIDTH
- W cr = CENTRAL RESERVE WIDTH
- W b-a = LANE WIDTH AVAILABLE TO VEHICLE WAITING IN STREAM b-a
- W b-c = LANE WIDTH AVAILABLE TO VEHICLE WAITING IN STREAM b-c
- W c-b = LANE WIDTH AVAILABLE TO VEHICLE WAITING IN STREAM c-b
- V b-a = VISIBILITY TO THE LEFT FOR VEHICLES WAITING IN STREAM b-a
- V r b-a = VISIBILITY TO THE RIGHT FOR VEHICLES WAITING IN STREAM b-a
- V r b-c = VISIBILITY TO THE RIGHT FOR VEHICLES WAITING IN STREAM b-c
- V r c-b = VISIBILITY TO THE RIGHT FOR VEHICLES WAITING IN STREAM c-b
- X a = STREAM-SPECIFIC (RIGHT TURN FROM A)
- X b = STREAM-SPECIFIC (RIGHT TURN FROM B)
- Z b = STREAM-SPECIFIC (LEFT TURN FROM B)
- M b = STREAM-SPECIFIC (STRAIGHT AHEAD FROM B - LEFT LANE)
- Y = (1-0.0345W)
- r b-a = RATIO OF FLOW TO CAPACITY IN STREAM b-a

GEOMETRIC DETAILS:

GENERAL						
W	=	7.80	(metres)	X a	=	0.959
W cr	=	3.40	(metres)	X d	=	0.977
				Z d	=	0.610
				M d	=	0.569
MAJOR ROAD (ARM A)						
W a-d	=	3.40	(metres)	W c-b	=	0.00
V r a-d	=	100	(metres)	V r c-b	=	0
q a-b	=	0	(pcu/hr)	q c-a	=	396
q a-c	=	299	(pcu/hr)	q c-b	=	0
q a-d	=	44	(pcu/hr)	q c-d	=	243
MINOR ROAD (ARM B)						
W b-a	=	0.00	(metres)	W d-c	=	5.00
W b-c	=	5.00	(metres)	W d-a	=	0.00
V l b-a	=	30	(metres)	V l d-c	=	40
V r b-a	=	18	(metres)	V r d-c	=	40
q b-a	=	17	(pcu/hr)	q d-a	=	305
q b-c	=	74	(pcu/hr)	q d-b	=	49
q b-d	=	21	(pcu/hr)	q d-b	=	0

GEOMETRIC FACTORS :

X b	=	0.554	X a	=	0.959
X c	=	0.586	X d	=	0.977
Z b	=	1.023	Z d	=	0.610
M b	=	0.950	M d	=	0.569
PROPORTION OF MINOR STRAIGHT AHEAD TRAFFIC :					
r b-a	=	0.0387	r d-c	=	0.695
q l b-d	=	10.907	q l d-b	=	0
q r b-d	=	10.093	q r d-b	=	0
CAPACITY OF MOVEMENT :					
Q b-a	=	257	Q d-c	=	439
Q b-c	=	674	Q d-a	=	309
Q c-b	=	380	Q a-d	=	551
Q l b-d	=	452	Q l d-b	=	272
Q r b-d	=	264	Q r d-b	=	486
Q b-acd	=	435	Q d-abc	=	415
				TOTAL FLOW =	1448 (PCU/HR)

COMPARISON OF DESIGN FLOW TO CAPACITY:

DFC b-a	=	0.0661
DFC b-c	=	0.1098
DFC c-b	=	0.0000
DFCI b-d	=	0.0241
DFCr b-d	=	0.0382
DFC d-c	=	0.6948
DFC d-a	=	0.1586
DFC a-d	=	0.0799
DFCI d-b	=	0.0000
DFCr d-b	=	0.0000
DFC b-acd (shared lane)	=	0.2577
DFC d-abc (shared lane)	=	0.8533

CRITICAL DFC = 0.85

LLA CONSULTANCY LIMITED

Application for Amendment of Plan under Section 12A for the Town Planning Ordinance (Cap. 131) for Mixed Use Development at Lot 796 and 1008RP in D.D. 77 and Adjoining Government Land in Ping Che, Ta Kwu Ling, New Territories

PRIORITY JUNCTION CALCULATION

2035 Design PM

PROJECT NO.: 40876
 FILENAME: J4_PCR_NCR.xlsx
 REFERENCE NO.:

INITIALS
 SKL
 SLN
 SLN

DATE
 Feb-24
 Feb-24
 Feb-24

J4 Ping Che Road / Ng Chow Road

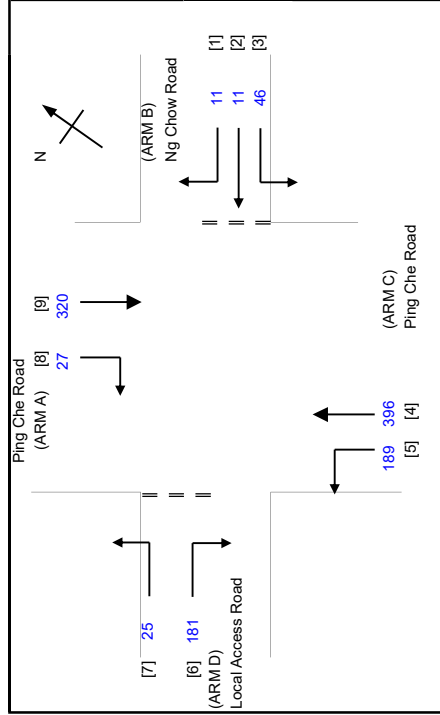

NOTES : (GEOMETRIC INPUT DATA)

- W = MAJOR ROAD WIDTH
- W cr = CENTRAL RESERVE WIDTH
- W b-a = LANE WIDTH AVAILABLE TO VEHICLE WAITING IN STREAM b-a
- W b-c = LANE WIDTH AVAILABLE TO VEHICLE WAITING IN STREAM b-c
- W c-b = LANE WIDTH AVAILABLE TO VEHICLE WAITING IN STREAM c-b
- V b-a = VISIBILITY TO THE LEFT FOR VEHICLES WAITING IN STREAM b-a
- V r b-a = VISIBILITY TO THE RIGHT FOR VEHICLES WAITING IN STREAM b-a
- V r b-c = VISIBILITY TO THE RIGHT FOR VEHICLES WAITING IN STREAM b-c
- V r c-b = VISIBILITY TO THE RIGHT FOR VEHICLES WAITING IN STREAM c-b
- X a = STREAM-SPECIFIC (RIGHT TURN FROM A)
- X b = STREAM-SPECIFIC (RIGHT TURN FROM B)
- Z b = STREAM-SPECIFIC (LEFT TURN FROM B)
- M b = STREAM-SPECIFIC (STRAIGHT AHEAD FROM B - LEFT LANE)
- Y = (1-0.0345W)
- r b-a = RATIO OF FLOW TO CAPACITY IN STREAM b-a

GEOMETRIC DETAILS:

GENERAL				
W =	7.80	(metres)		
W cr =	3.40	(metres)	Y =	0.731
MAJOR ROAD (ARM A)				
W a-d =	3.40	(metres)	W c-b =	0.00
V r a-d =	100	(metres)	V r c-b =	0
q a-b =	0	(pcu/hr)	q c-a =	396
q a-c =	320	(pcu/hr)	q c-b =	0
q a-d =	27	(pcu/hr)	q c-d =	189
MINOR ROAD (ARM B)				
W b-a =	0.00	(metres)	W d-c =	5.00
W b-c =	5.00	(metres)	W d-a =	0.00
V l b-a =	30	(metres)	V l d-c =	40
V r b-a =	18	(metres)	V r d-c =	40
q b-a =	11	(pcu/hr)	q d-c =	181
q b-c =	46	(pcu/hr)	q d-a =	25
q b-d =	11	(pcu/hr)	q d-b =	0

GEOMETRIC FACTORS :

X b =	0.554	X a =	0.959
X c =	0.586	X d =	0.977
Z b =	1.023	Z d =	0.610
M b =	0.950	M d =	0.569
PROPORTION OF MINOR STRAIGHT AHEAD TRAFFIC :			
r b-a =	0.024	r d-c =	0.395
q l b-d =	5.6321	q l d-b =	0
q r b-d =	5.3679	q r d-b =	0
CAPACITY OF MOVEMENT :			
Q b-a =	269	Q d-c =	458
Q b-c =	671	Q d-a =	340
Q c-b =	381	Q a-d =	565
Q l b-d =	460	Q l d-b =	276
Q r b-d =	268	Q r d-b =	474
Q b-acd =	452	Q d-abc =	439
TOTAL FLOW =		1206 (PCU/HR)	

COMPARISON OF DESIGN FLOW TO CAPACITY:

DFC b-a =	0.0409
DFC b-c =	0.0686
DFC c-b =	0.0000
DFCI b-d =	0.0122
DFCr b-d =	0.0200
DFC d-c =	0.3952
DFC d-a =	0.0735
DFC a-d =	0.0478
DFCI d-b =	0.0000
DFCr d-b =	0.0000
DFC b-acd (shared lane) =	0.1503
DFC d-abc (shared lane) =	0.4687

CRITICAL DFC = 0.47

LLA CONSULTANCY LIMITED

Application for Amendment of Plan under Section 12A for the Town Planning Ordinance (Cap. 131) for Mixed Use Development at Lot 796 and 1008RP in D.D. 77 and Adjoining Government Land in Ping Che, Ta Kwu Ling, New Territories

J5 Sha Tau Kok Road / Lung Ma Road

ROUNDABOUT CALCULATION

PROJECT NO.: 40876
 FILENAME: J5_STKR_LMR.xls
 REFERENCE NO.:
 PREPARED BY: SKL
 CHECKED BY: SLN
 REVIEWED BY: SLN
 DATE: Feb-24

2035 Reference AM

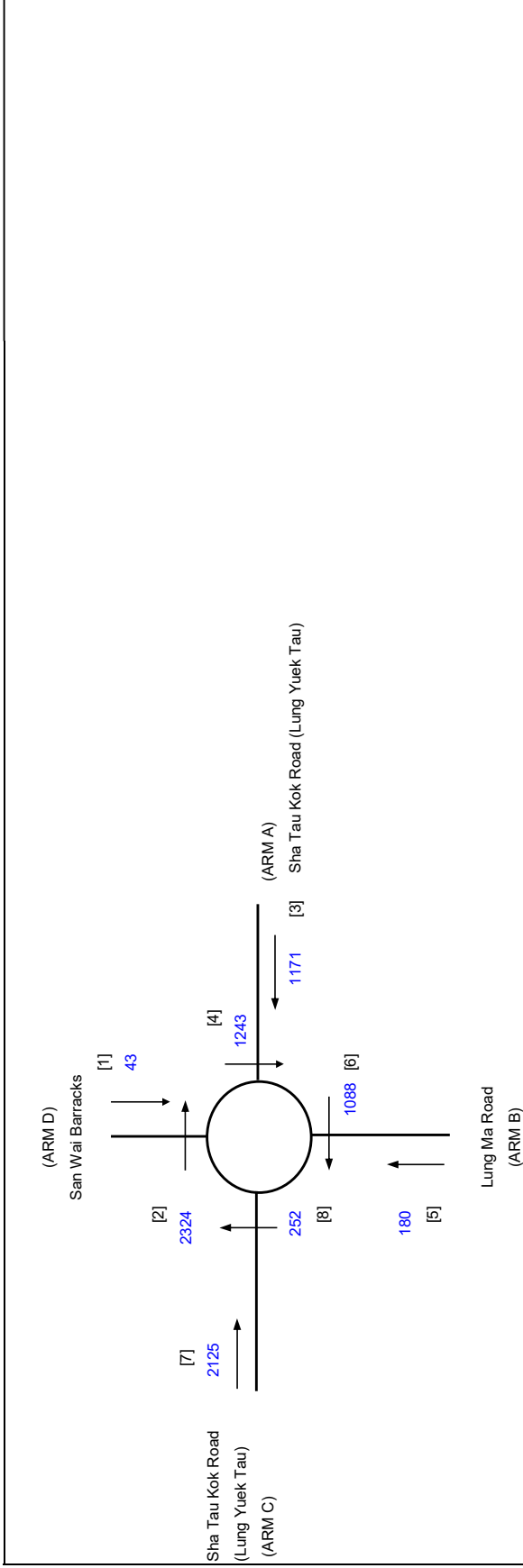

ARM

INPUT PARAMETERS:

	A	B	C	D
V = Approach half width (m)	7.30	3.50	7.30	3.00
E = Entry width (m)	10.00	7.00	9.50	5.00
L = Effective length of flare (m)	11.00	20.00	30.00	15.00
R = Entry radius (m)	20.00	100.00	30.00	35.00
D = Inscribed circle diameter (m)	55.00	55.00	55.00	55.00
A = Entry angle (degree)	20.00	10.00	9.00	15.00
Q = Entry flow (pcu/h)	1171	180	2125	43
Qc = Circulating flow across entry (pcu/h)	1243	1088	252	2324

OUTPUT PARAMETERS:

S = Sharpness of flare = $1.6(E-V)/L$	0.39	0.28	0.12	0.21
K = $1-0.00347(A-30)-0.978(1/R-0.05)$	1.03	1.11	1.09	1.07
X2 = $V + ((E-V)/(1+2S))$	8.81	5.74	9.08	4.40
M = $EXP((D-60)/10)$	0.61	0.61	0.61	0.61
F = $303*X2$	2670	1740	2752	1334
Td = $1+(0.5/(1+M))$	1.31	1.31	1.31	1.31
Fc = $0.21*Td(1+0.2*X2)$	0.76	0.59	0.78	0.52
Qe = $K(F-Fc*Qc)$	1784	1216	2784	140
DFC = Design flow/Capacity = Q/Qe	0.66	0.15	0.76	0.31

Total In Sum =

3519 PCU

DFC of Critical Approach =

0.76

LLA CONSULTANCY LIMITED

Application for Amendment of Plan under Section 12A for the Town Planning Ordinance (Cap. 131) for Mixed Use Development at Lot 796 and 1008RP in D.D. 77 and Adjoining Government Land in Ping Che, Ta Kwu Ling, New Territories

J5 Sha Tau Kok Road / Lung Ma Road

ROUNDABOUT CALCULATION

PROJECT NO.: 40876
 FILENAME: J5_STKR_LMR.xls
 REFERENCE NO.:
 PREPARED BY: SKL
 CHECKED BY: SLN
 REVIEWED BY: SLN
 DATE: Feb-24

2035 Reference PM

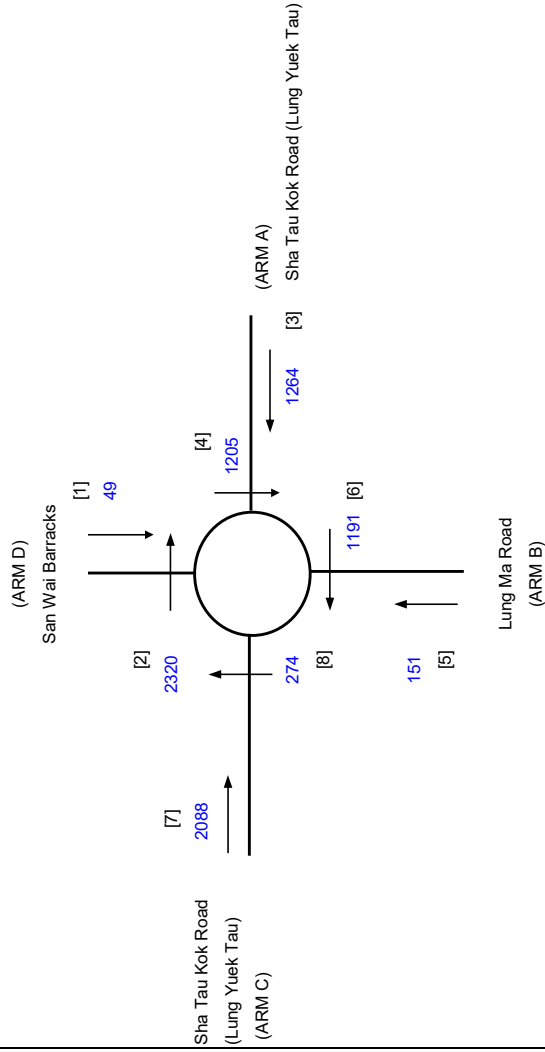

ARM

INPUT PARAMETERS:

	A	B	C	D
V = Approach half width (m)	7.30	3.50	7.30	3.00
E = Entry width (m)	10.00	7.00	9.50	5.00
L = Effective length of flare (m)	11.00	20.00	30.00	15.00
R = Entry radius (m)	20.00	100.00	30.00	35.00
D = Inscribed circle diameter (m)	55.00	55.00	55.00	55.00
A = Entry angle (degree)	20.00	10.00	9.00	15.00
Q = Entry flow (pcu/h)	1264	151	2088	49
Qc = Circulating flow across entry (pcu/h)	1205	1191	274	2320

OUTPUT PARAMETERS:

S = Sharpness of flare = $1.6(E-V)/L$	0.39	0.28	0.12	0.21
K = $1-0.00347(A-30)-0.978(1/R-0.05)$	1.03	1.11	1.09	1.07
X2 = $V + ((E-V)/(1+2S))$	8.81	5.74	9.08	4.40
M = $EXP((D-60)/10)$	0.61	0.61	0.61	0.61
F = $303*X2$	2670	1740	2752	1334
Td = $1+(0.5/(1+M))$	1.31	1.31	1.31	1.31
Fc = $0.21*Td(1+0.2*X2)$	0.76	0.59	0.78	0.52
Qe = $K(F-Fc*Qc)$	1814	1148	2766	142
DFC = Design flow/Capacity = Q/Qe	0.70	0.13	0.75	0.34

Total In Sum =

3552 PCU

DFC of Critical Approach =

0.75

LLA CONSULTANCY LIMITED

Application for Amendment of Plan under Section 12A for the Town Planning Ordinance (Cap. 131) for Mixed Use Development at Lot 796 and 1008RP in D.D. 77 and Adjoining Government Land in Ping Che, Ta Kwu Ling, New Territories

J5 Sha Tau Kok Road / Lung Ma Road

ROUNDABOUT CALCULATION

PROJECT NO.: 40876
 FILENAME: J5_STKR_LMR.xls
 REFERENCE NO.:
 PREPARED BY: SKL
 CHECKED BY: SLN
 REVIEWED BY: SLN
 DATE: Feb-24

2035 Design AM

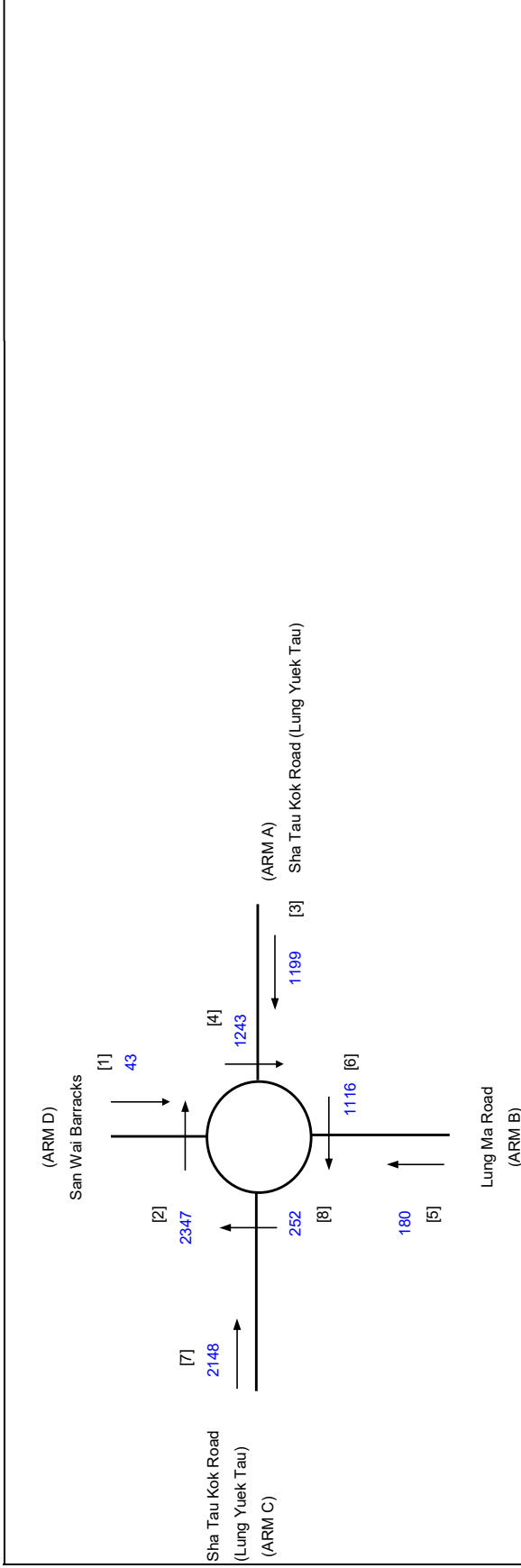

ARM

INPUT PARAMETERS:

	A	B	C	D
V = Approach half width (m)	7.30	3.50	7.30	3.00
E = Entry width (m)	10.00	7.00	9.50	5.00
L = Effective length of flare (m)	11.00	20.00	30.00	15.00
R = Entry radius (m)	20.00	100.00	30.00	35.00
D = Inscribed circle diameter (m)	55.00	55.00	55.00	55.00
A = Entry angle (degree)	20.00	10.00	9.00	15.00
Q = Entry flow (pcu/h)	1199	180	2148	43
Qc = Circulating flow across entry (pcu/h)	1243	1116	252	2347

OUTPUT PARAMETERS:

S = Sharpness of flare = $1.6(E-V)/L$	0.39	0.28	0.12	0.21
K = $1-0.00347(A-30)-0.978(1/R-0.05)$	1.03	1.11	1.09	1.07
X2 = $V + ((E-V)/(1+2S))$	8.81	5.74	9.08	4.40
M = $EXP((D-60)/10)$	0.61	0.61	0.61	0.61
F = $303*X2$	2670	1740	2752	1334
Td = $1+(0.5/(1+M))$	1.31	1.31	1.31	1.31
Fc = $0.21*Td(1+0.2*X2)$	0.76	0.59	0.78	0.52
Qe = $K(F-Fc*Qc)$	1784	1197	2784	127
DFC = Design flow/Capacity = Q/Qe	0.67	0.15	0.77	0.34

Total In Sum = 3570 PCU

DFC of Critical Approach = 0.77

LLA CONSULTANCY LIMITED

Application for Amendment of Plan under Section 12A for the Town Planning Ordinance (Cap. 131) for Mixed Use Development at Lot 796 and 1008RP in D.D. 77 and Adjoining Government Land in Ping Che, Ta Kwu Ling, New Territories

J5 Sha Tau Kok Road / Lung Ma Road

ROUNDABOUT CALCULATION

PROJECT NO.: 40876
 FILENAME: J5_STKR_LMR.xls
 REFERENCE NO.:
 PREPARED BY: SKL
 CHECKED BY: SLN
 REVIEWED BY: SLN
 DATE: Feb-24

2035 Design PM

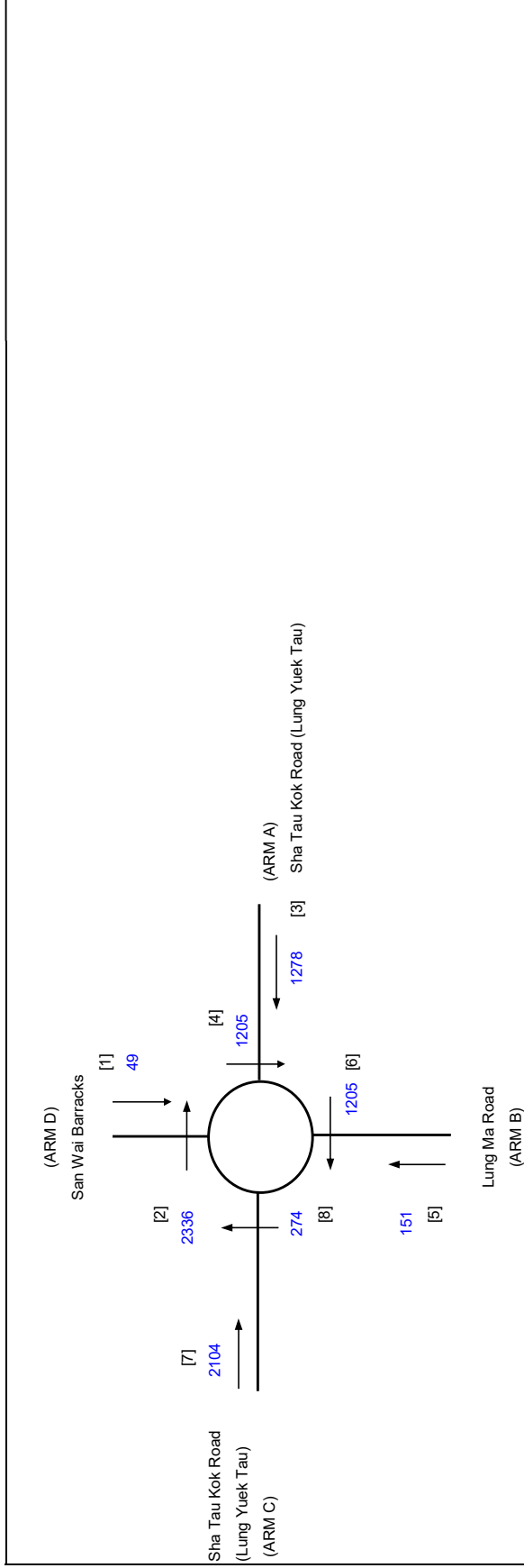

ARM

INPUT PARAMETERS:

	A	B	C	D
V = Approach half width (m)	7.30	3.50	7.30	3.00
E = Entry width (m)	10.00	7.00	9.50	5.00
L = Effective length of flare (m)	11.00	20.00	30.00	15.00
R = Entry radius (m)	20.00	100.00	30.00	35.00
D = Inscribed circle diameter (m)	55.00	55.00	55.00	55.00
A = Entry angle (degree)	20.00	10.00	9.00	15.00
Q = Entry flow (pcu/h)	1278	151	2104	49
Qc = Circulating flow across entry (pcu/h)	1205	1205	274	2336

OUTPUT PARAMETERS:

S = Sharpness of flare = $1.6(E-V)/L$	0.39	0.28	0.12	0.21
K = $1-0.00347(A-30)-0.978(1/R-0.05)$	1.03	1.11	1.09	1.07
X2 = $V + ((E-V)/(1+2S))$	8.81	5.74	9.08	4.40
M = $EXP((D-60)/10)$	0.61	0.61	0.61	0.61
F = $303*X2$	2670	1740	2752	1334
Td = $1+(0.5/(1+M))$	1.31	1.31	1.31	1.31
Fc = $0.21*Td(1+0.2*X2)$	0.76	0.59	0.78	0.52
Qe = $K(F-Fc*Qc)$	1814	1139	2766	133

DFC = Design flow/Capacity = Q/Qe

Total In Sum = 3582 PCU

DFC of Critical Approach = 0.76

Appendix C
Preliminary Car Park Layout Plan and
Swept Path Analysis

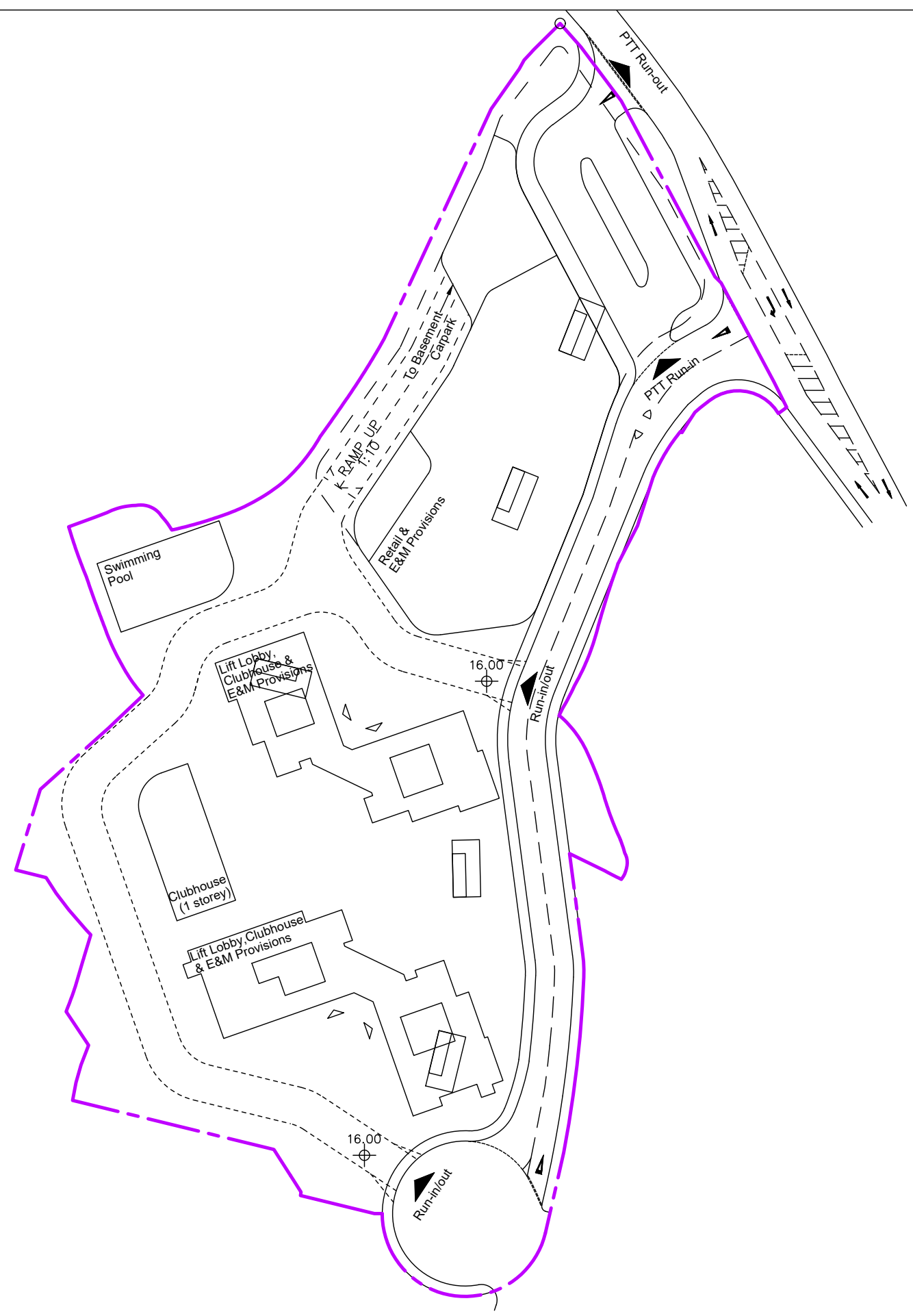

GROUND FLOOR
(SCALE 1:1000 @ A3)

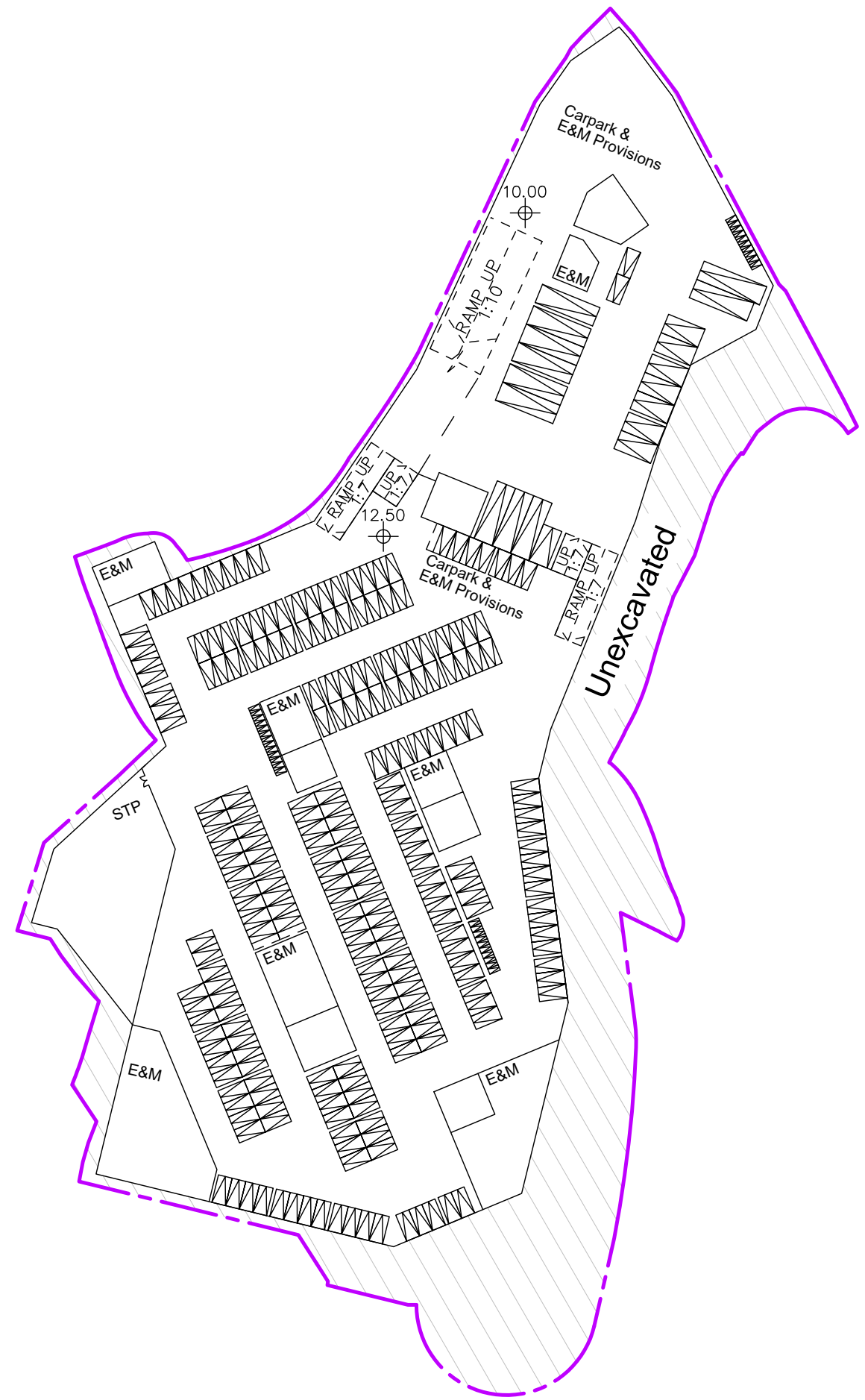

PC: 238
LGV: 8
HGV: 10
Tour Bus: 1
Motorcycle: 11
Lay-by PC : 2

BASEMENT 1 FLOOR
(SCALE 1:1000 @ A3)

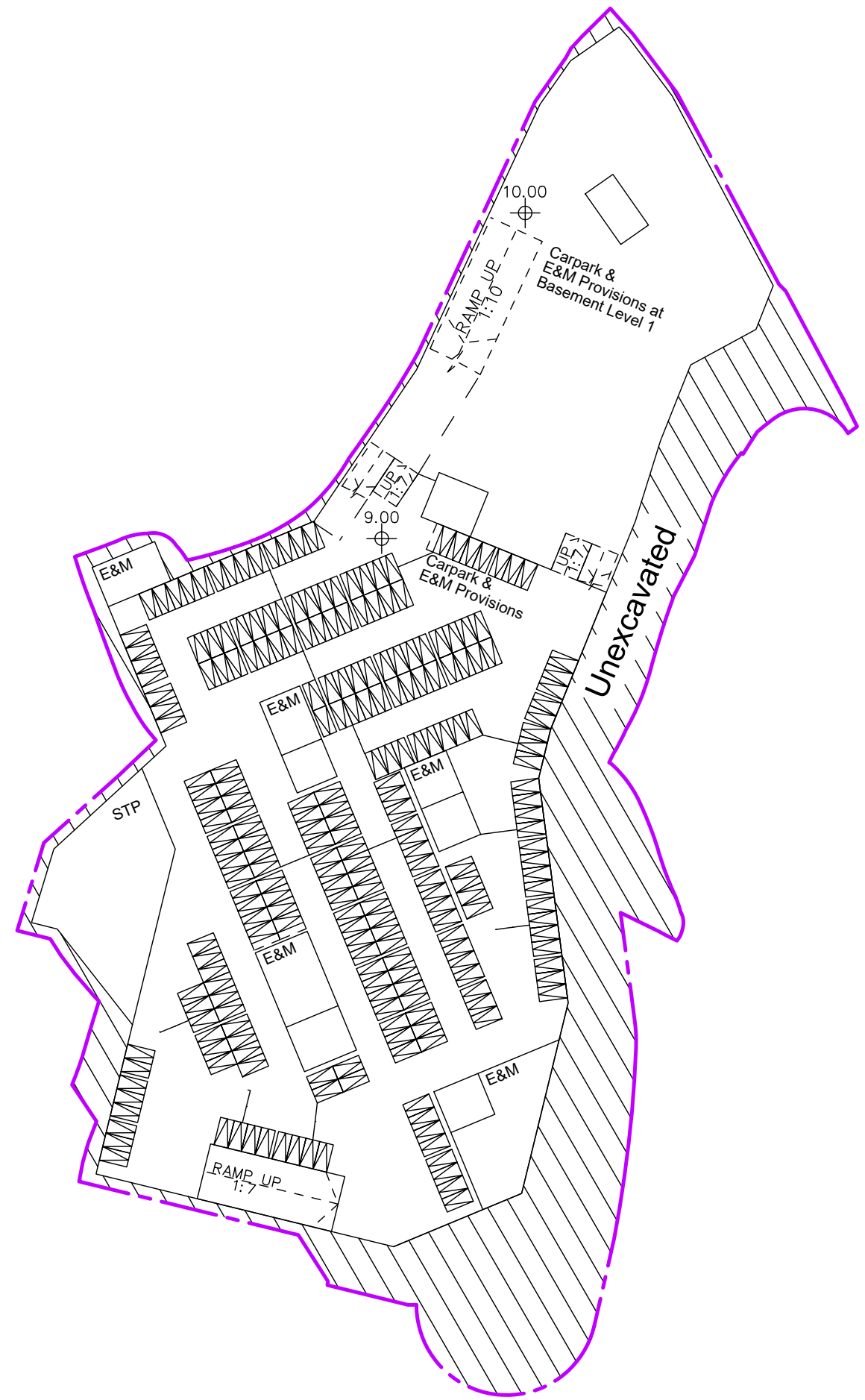

PC: 242
Motorcycle: 11

BASEMENT 2 FLOOR
(SCALE 1:1000 @ A3)

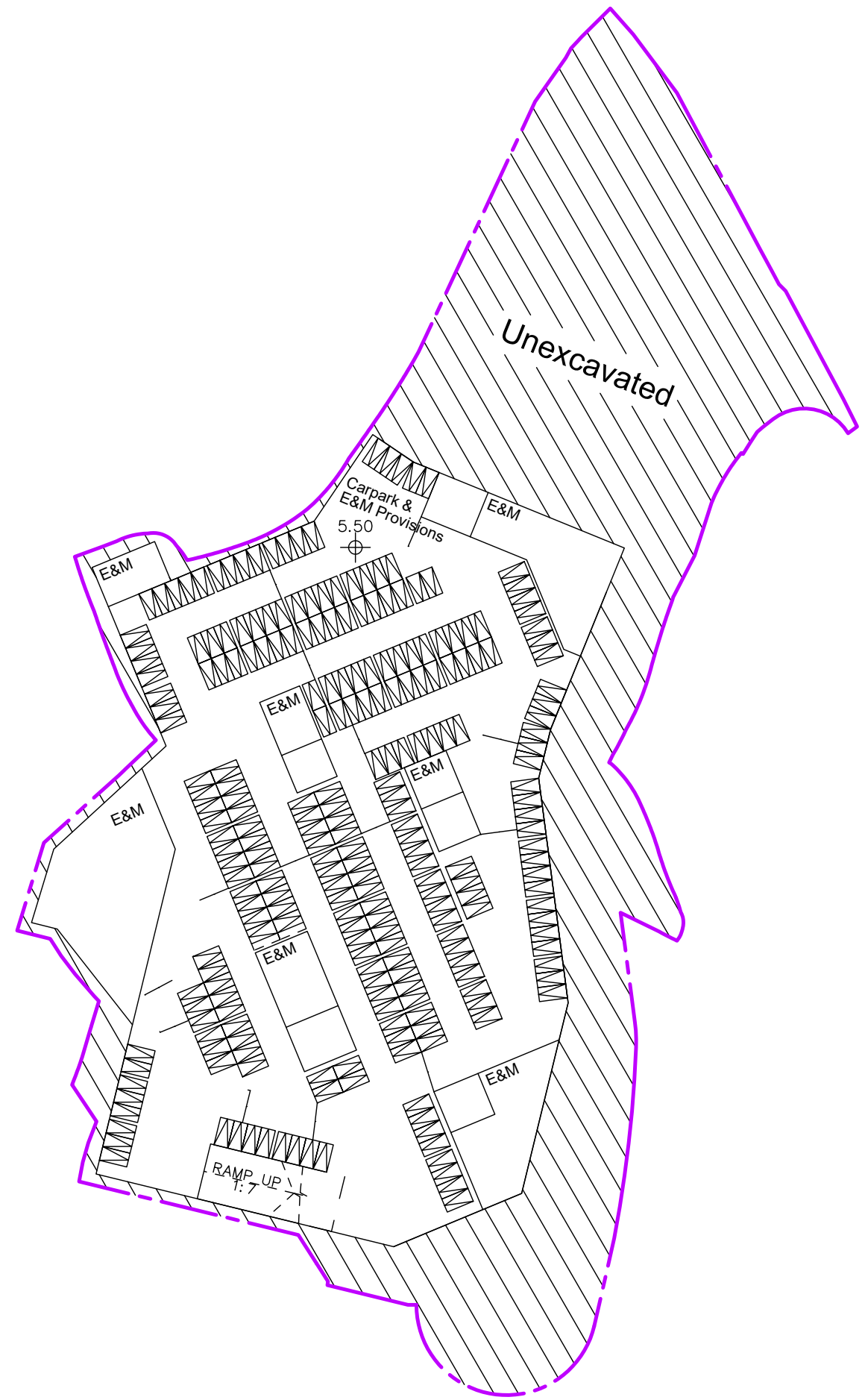

PC: 245
Motorcycle: 11

BASEMENT 3 FLOOR
(SCALE 1:1000 @ A3)

STEP 1

STEP 2

STEP 3

STEP 4

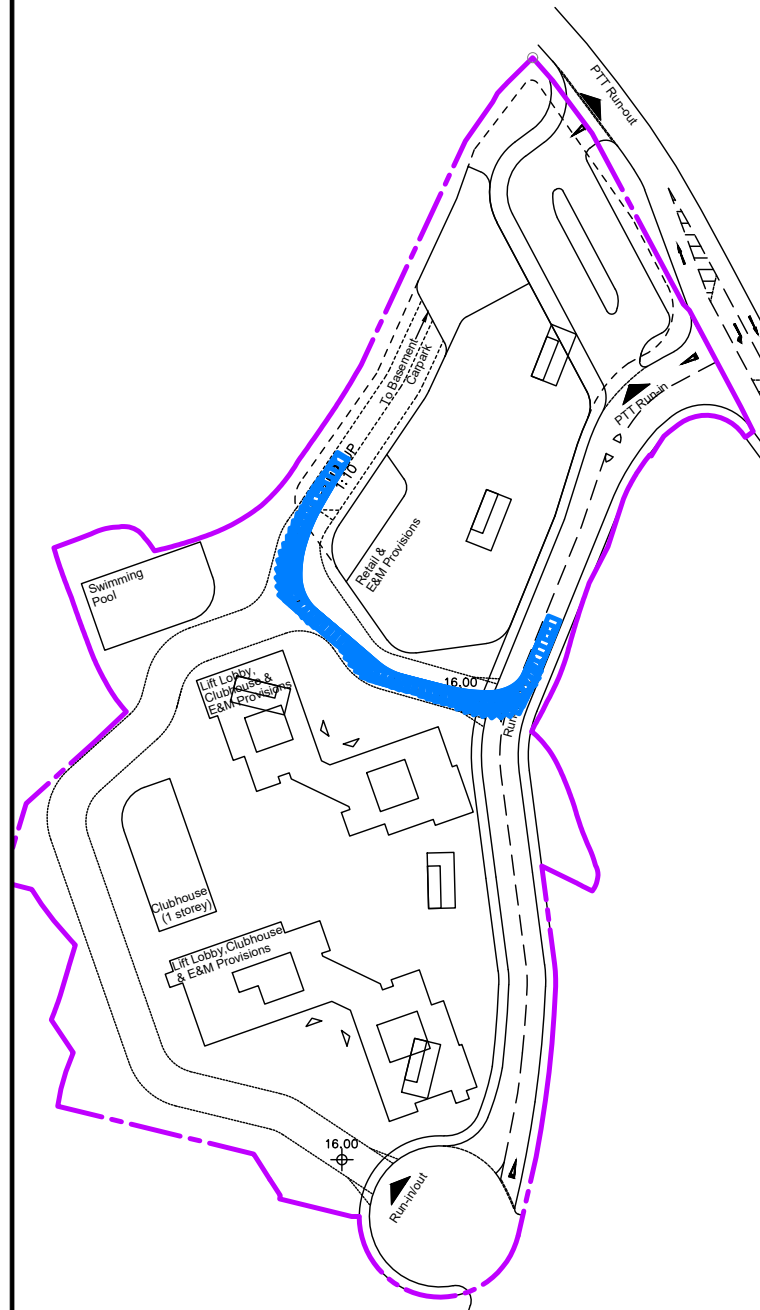

ENTERING FROM GF TO B1

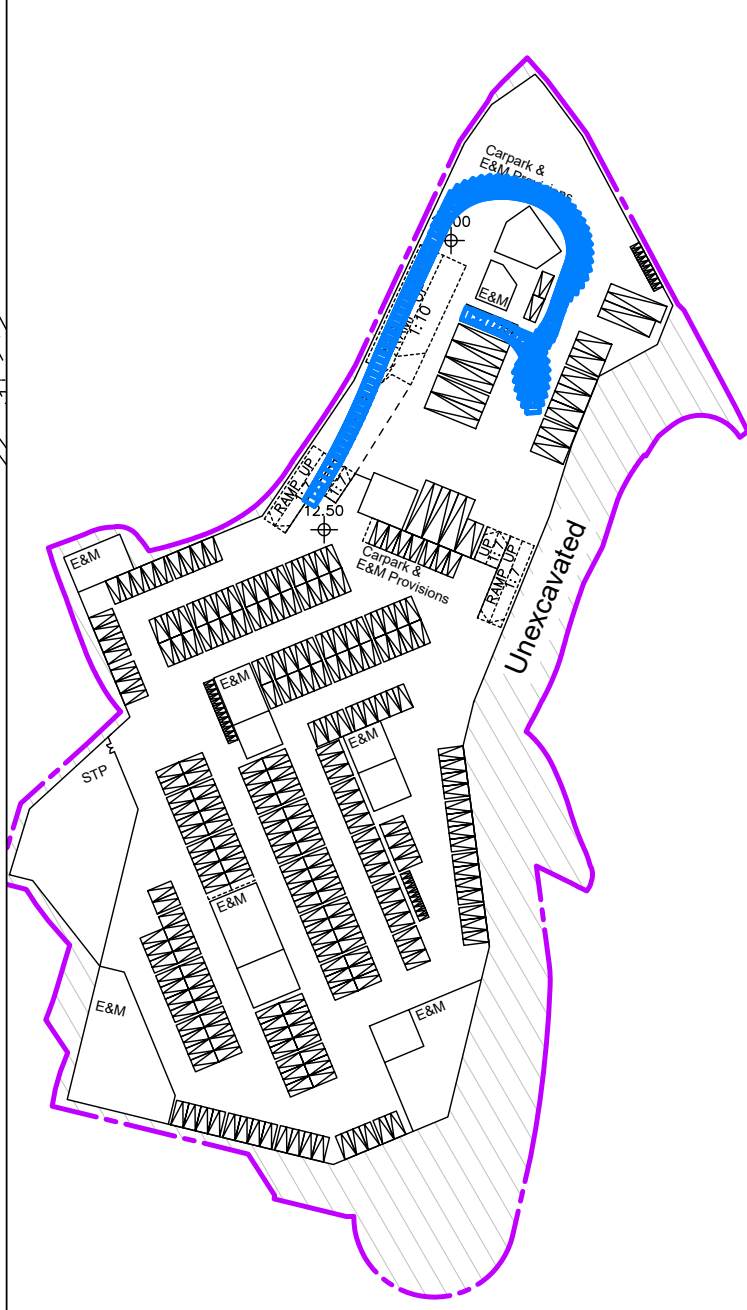

PARKING AT B1

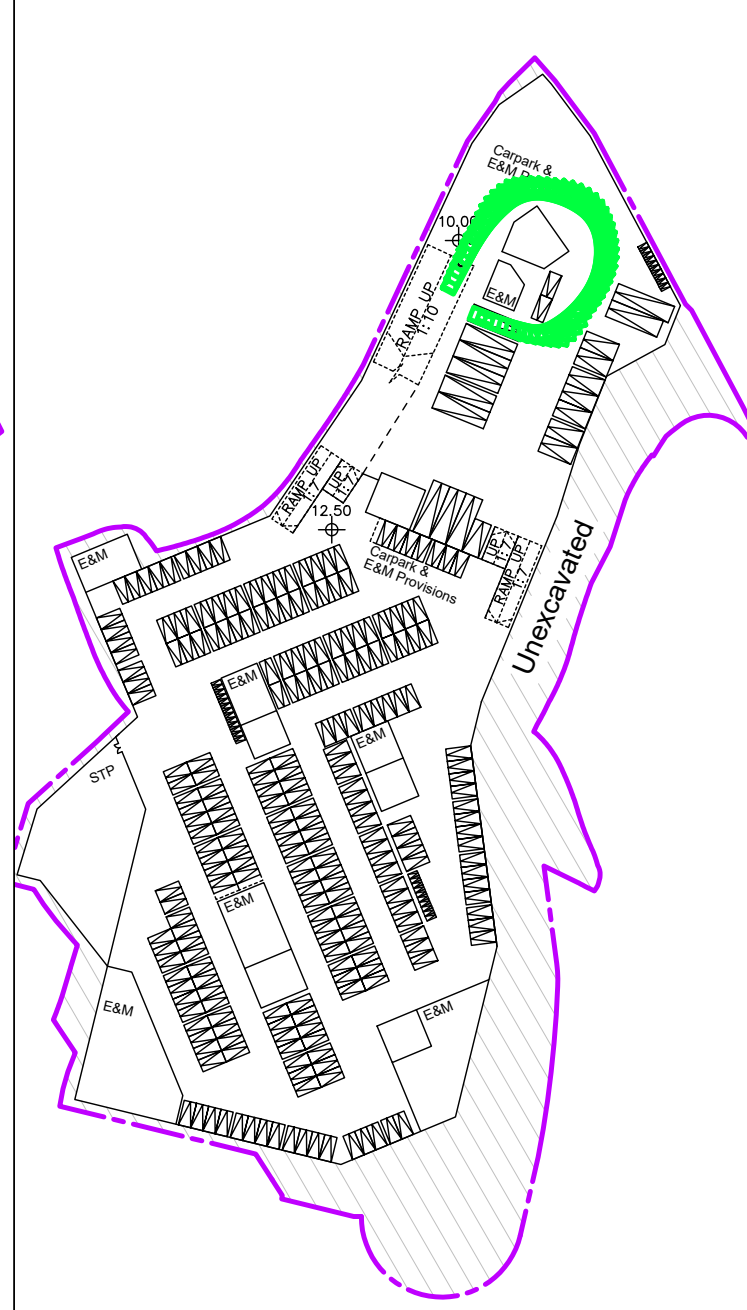

LEAVEING FROM PARKING SPACE AT B1

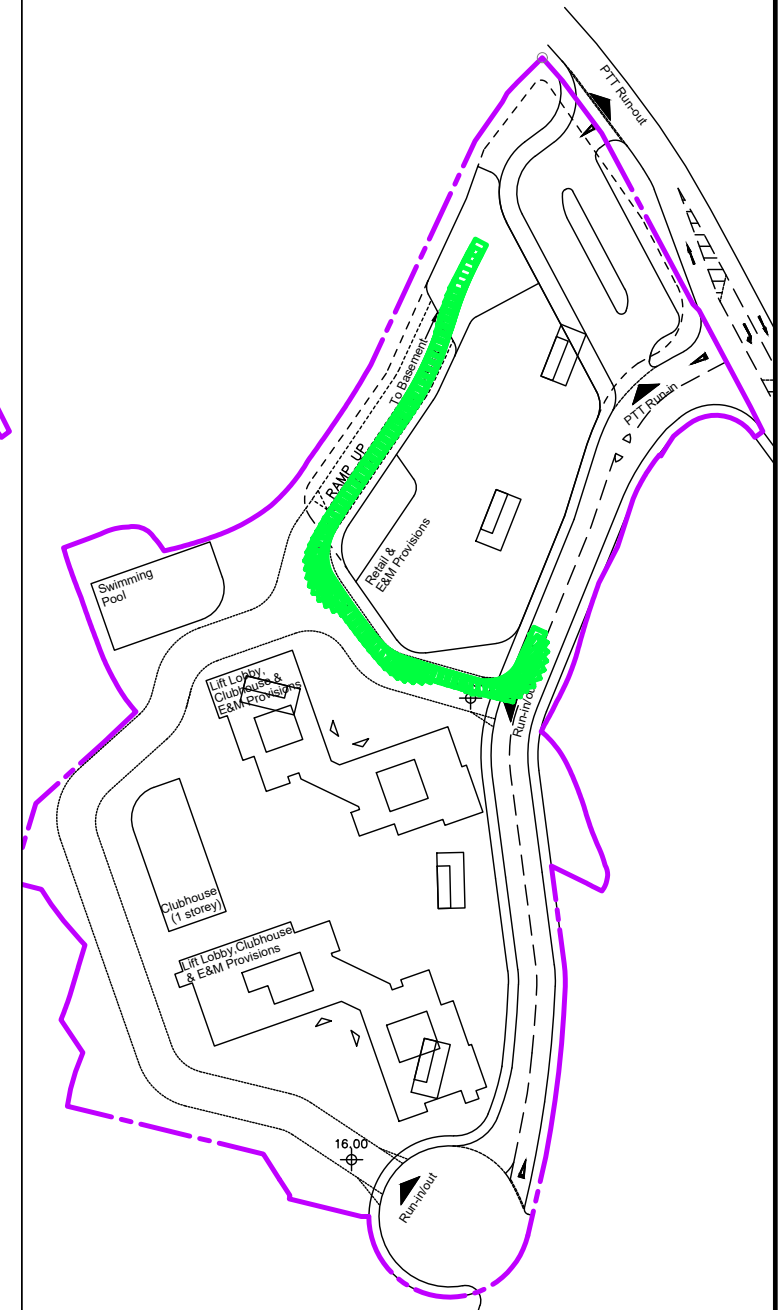

LEAVGING FROM B1 TO GF

PROJECT NO.	40876
DESIGNED	SKL
DRAWN	CLL
CHECKED	SLN
DATE	MAR 2024
SCALE	1:1500 @ A3

PROJECT TITLE: RESIDENTIAL DEVELOPMENT AT PING CHE D.D.77 LOT 796 & 1008 RP - TIA STUDY FOR S12A REZONING APPLICATION

DRAWING NO.	SP-01
REV.	.

SWEPT PATH ANALYSIS - HGV

LLA 顧問有限公司
Consultancy Limited

STEP 1

STEP 2

STEP 3

STEP 4

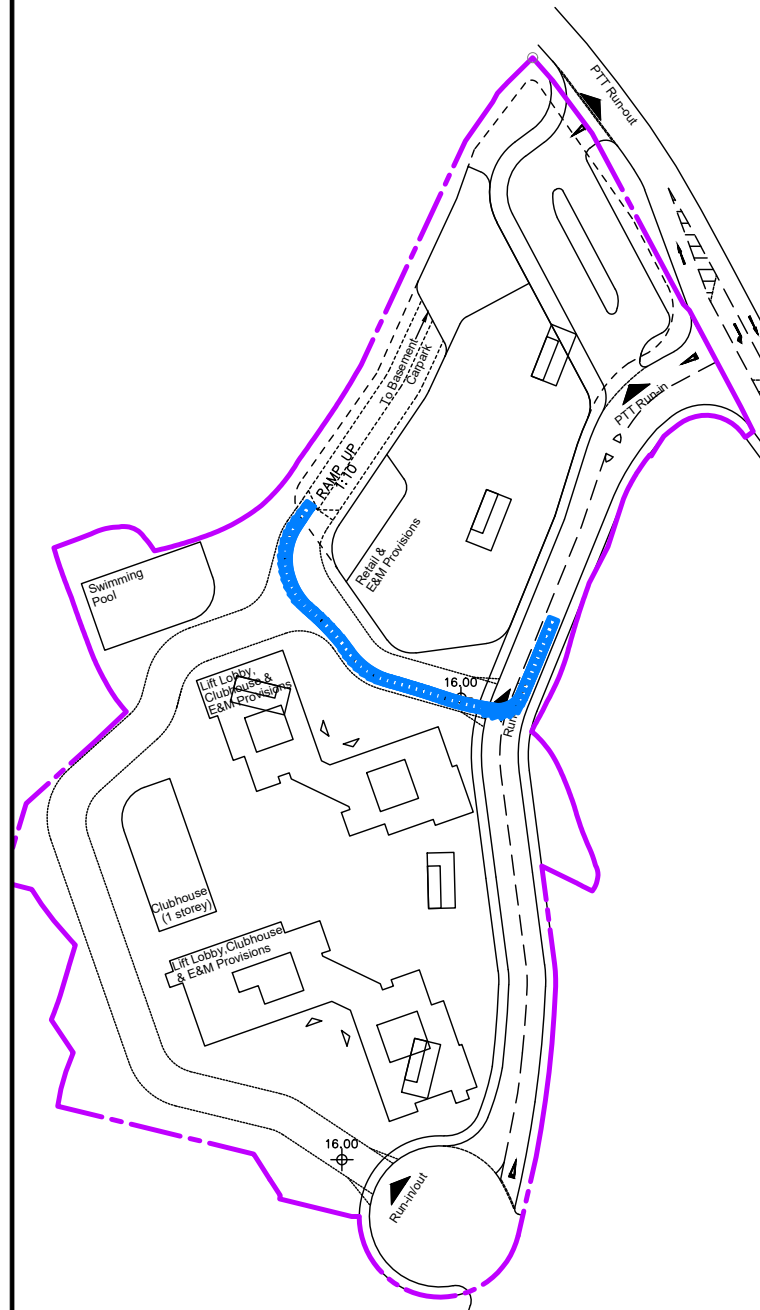

ENTERING FROM GF TO B1

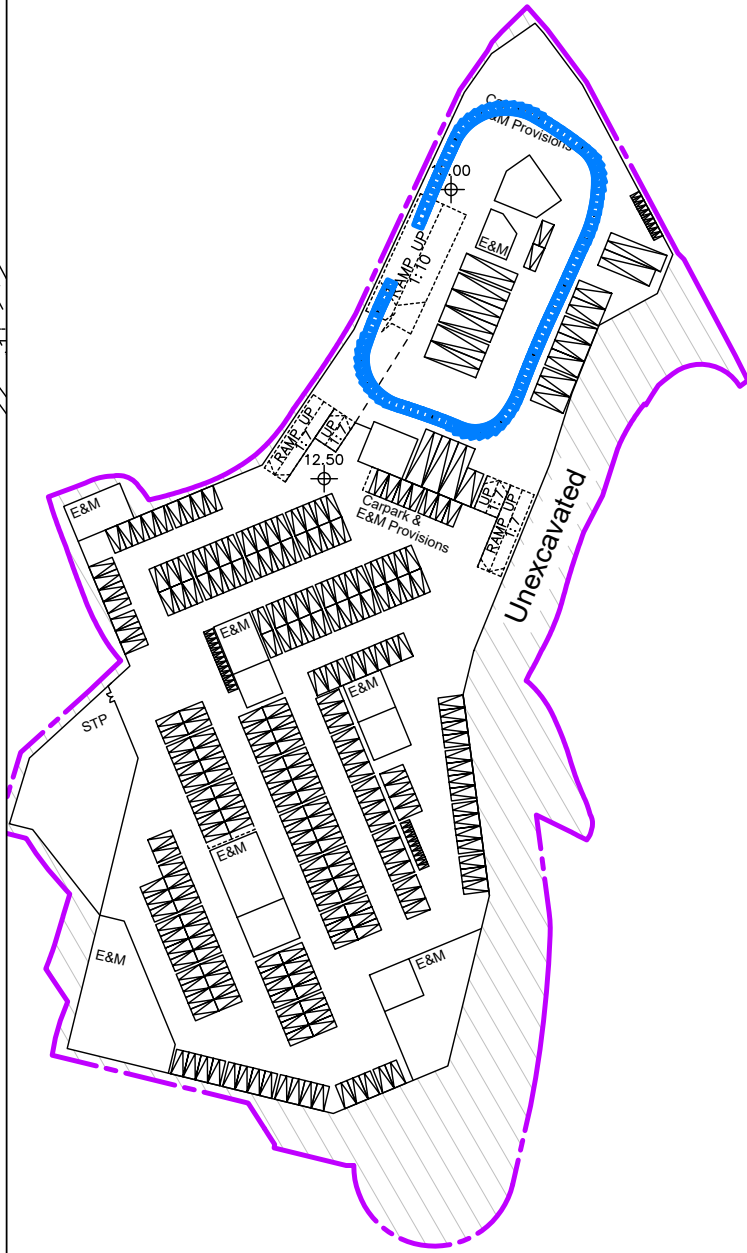

B1 TO B2

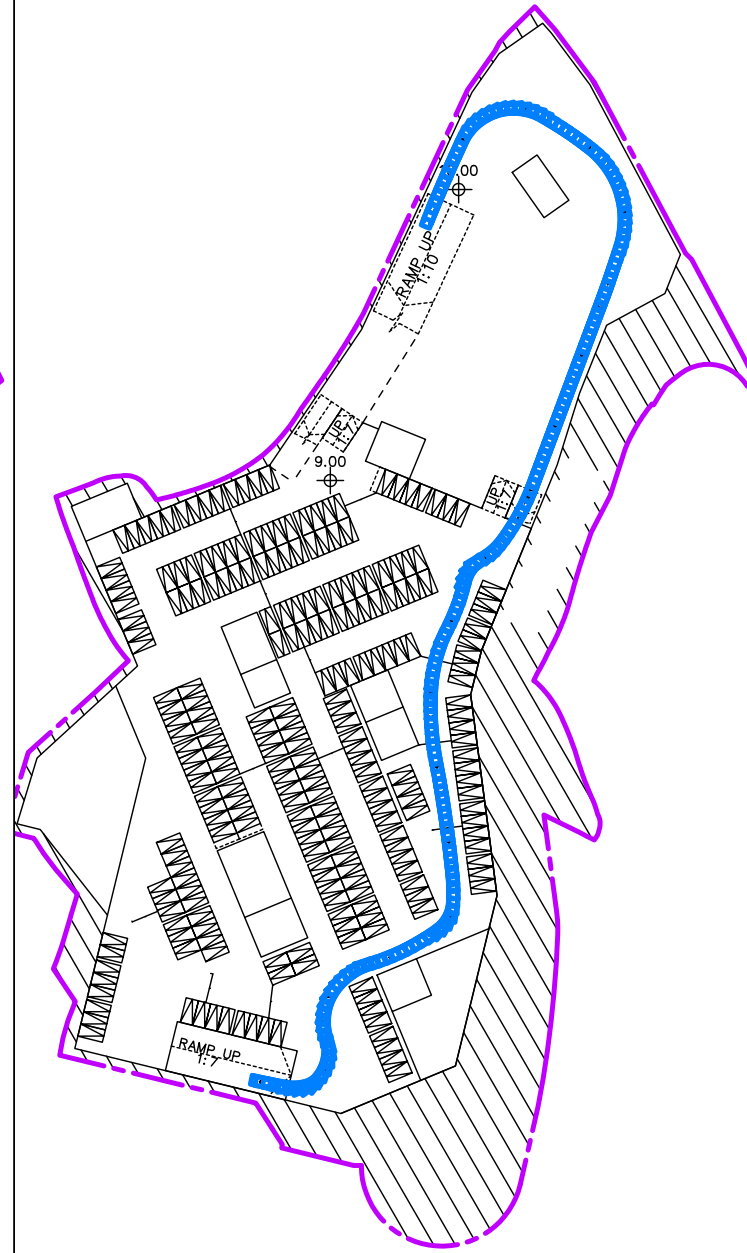

B2 TO B3

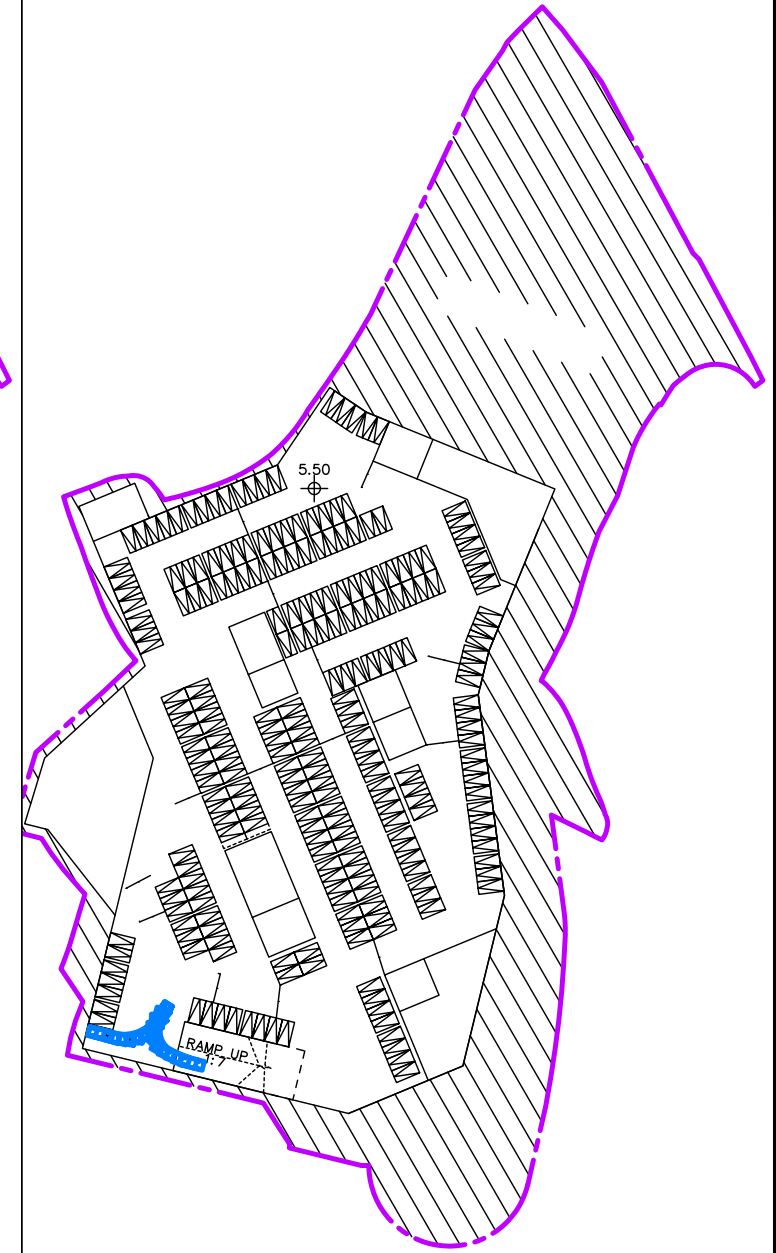

PARKING AT B3

PROJECT NO.	40876
DESIGNED	SKL
DATE	MAR 2024
DRAWN	CLL
CHECKED	SLN
SCALE	1:1500 @ A3

PROJECT TITLE: RESIDENTIAL DEVELOPMENT AT PING CHE D.D.77 LOT 796 & 1008 RP - TIA STUDY FOR S12A REZONING APPLICATION

DRAWING NO.	SP-02
REV.	.

SWEPT PATH ANALYSIS - PC

LLA 顧問有限公司
Consultancy Limited

STEP 1

STEP 2

STEP 3

STEP 4

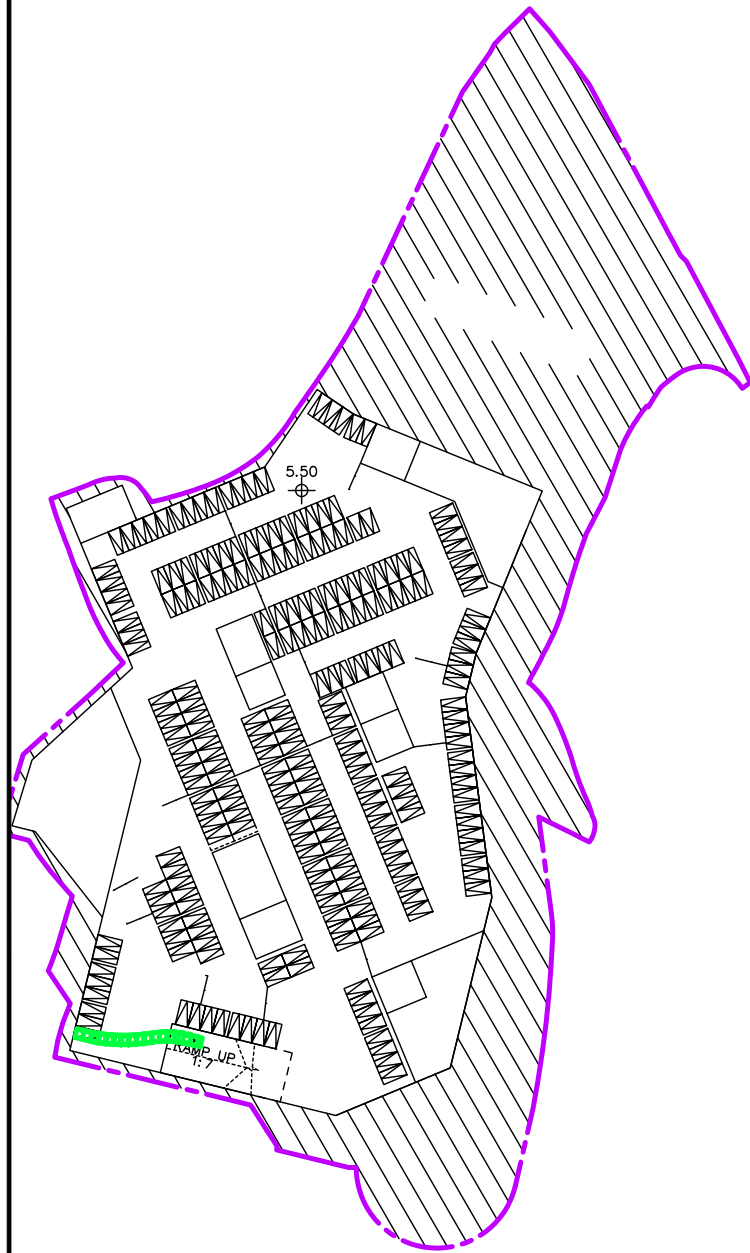

LEAVING PARKING SPACE AT B3

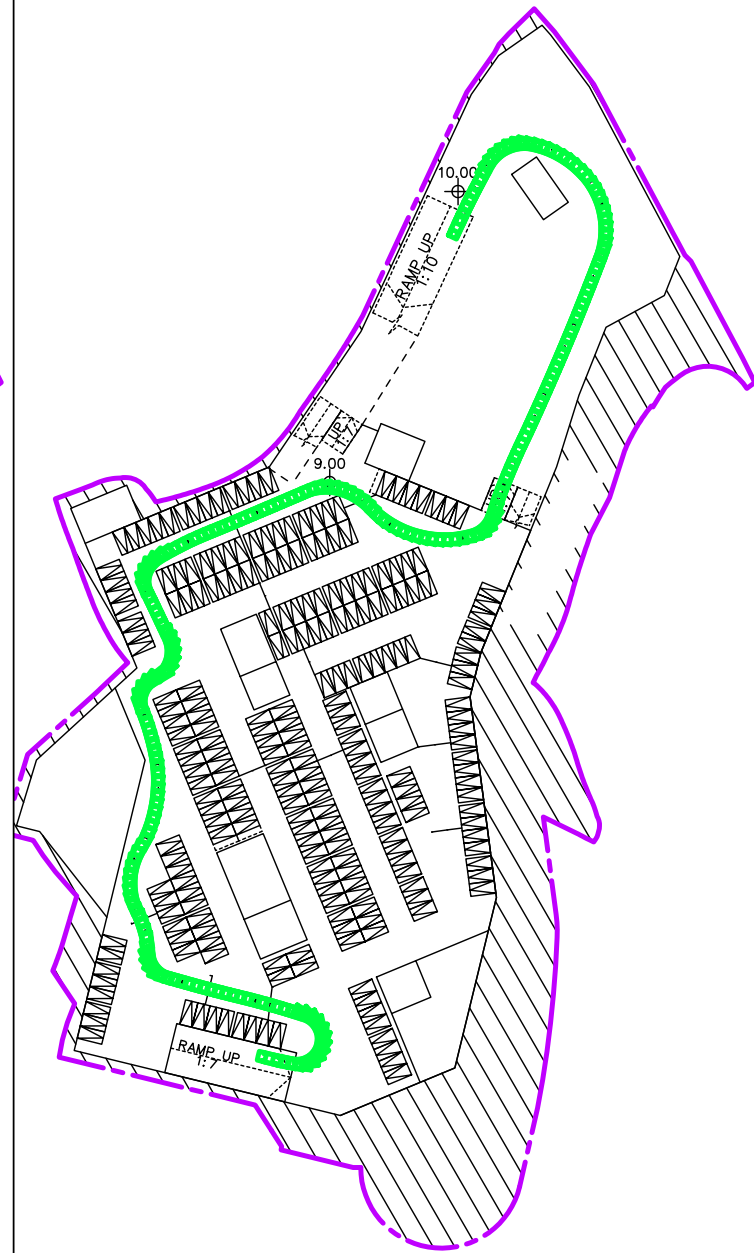

B2

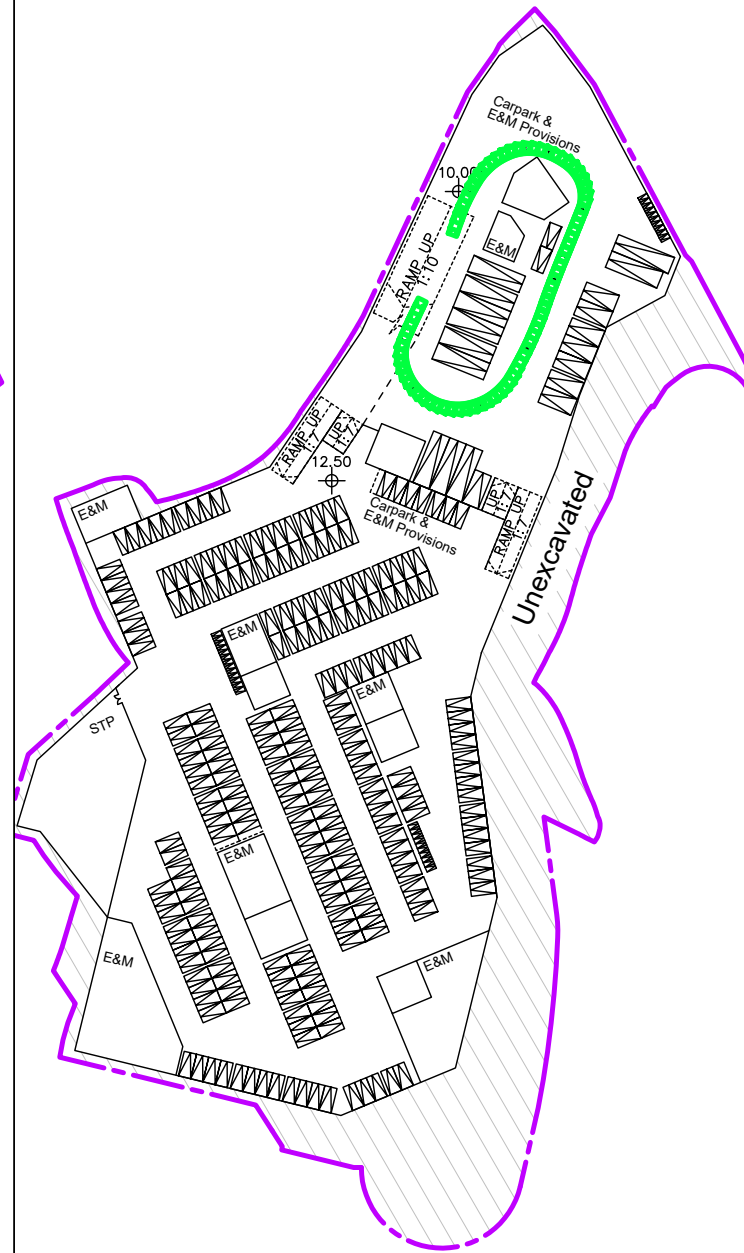

B1

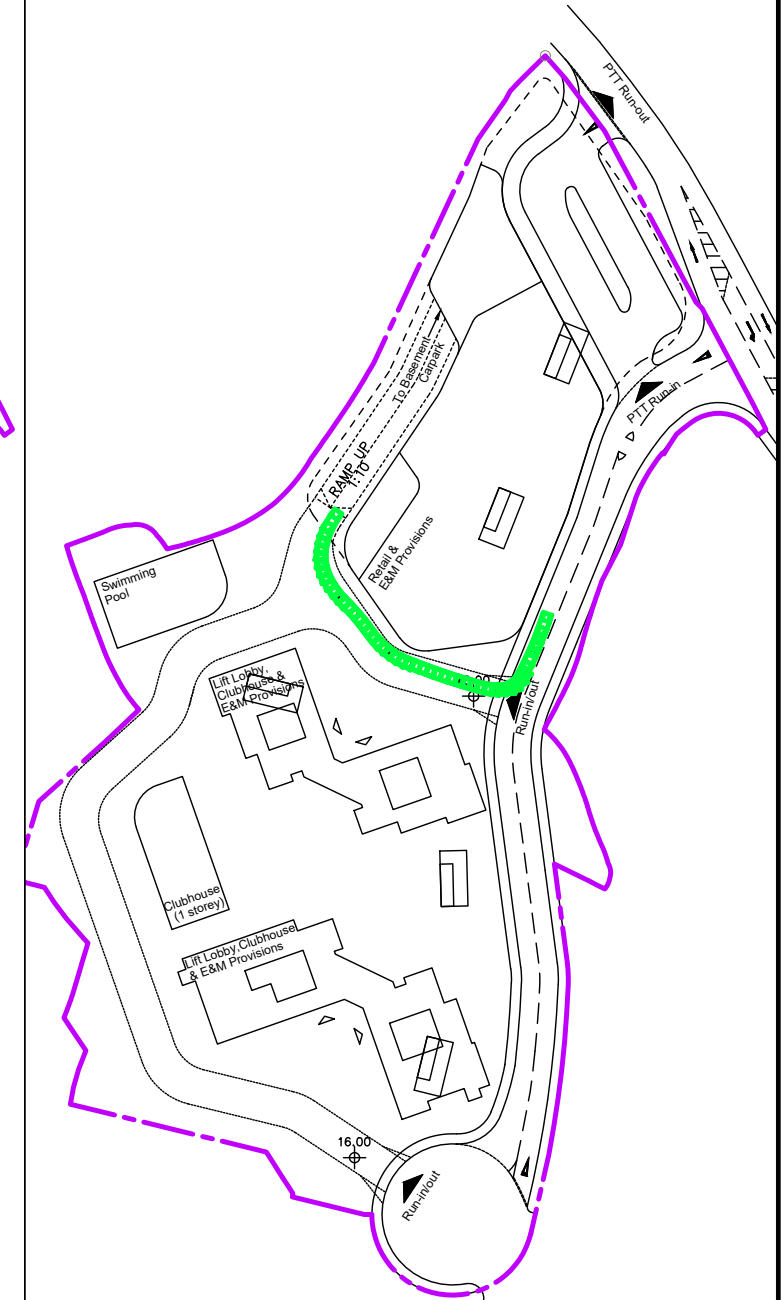

GF

PROJECT NO.	40876
DESIGNED	SKL
DRAWN	CLL
CHECKED	SLN
DATE	MAR 2024
SCALE	1:1500 @ A3

PROJECT TITLE: RESIDENTIAL DEVELOPMENT AT PING CHE D.D.77 LOT 796 & 1008 RP - TIA STUDY FOR S12A REZONING APPLICATION

DRAWING NO.	SP-03
REV.	.

SWEPT PATH ANALYSIS - PC

LLA 顧問有限公司
Consultancy Limited